

ENTERPRISE PUBLICITY

Create a new space for quality life

Committed to the sustainable development of the company, to become the benchmark of the acoustic materials industry Exceed customer expectations

CONTANTS

01

COMPANY INTRODUCTION

02

PRODUCT INTRODUCTION

03

ENGINEERING CASE

Southern Jiangsu
new way of
through
to
and
td: is
als,

ACOUSTIC SLAT PANEL
PRODUCTION WORKSHOP



Grille Plate Production Workshop



Grid Plate Production Line



Grille Panel Automation Products Plastic Sealing



Product Plastic Seal

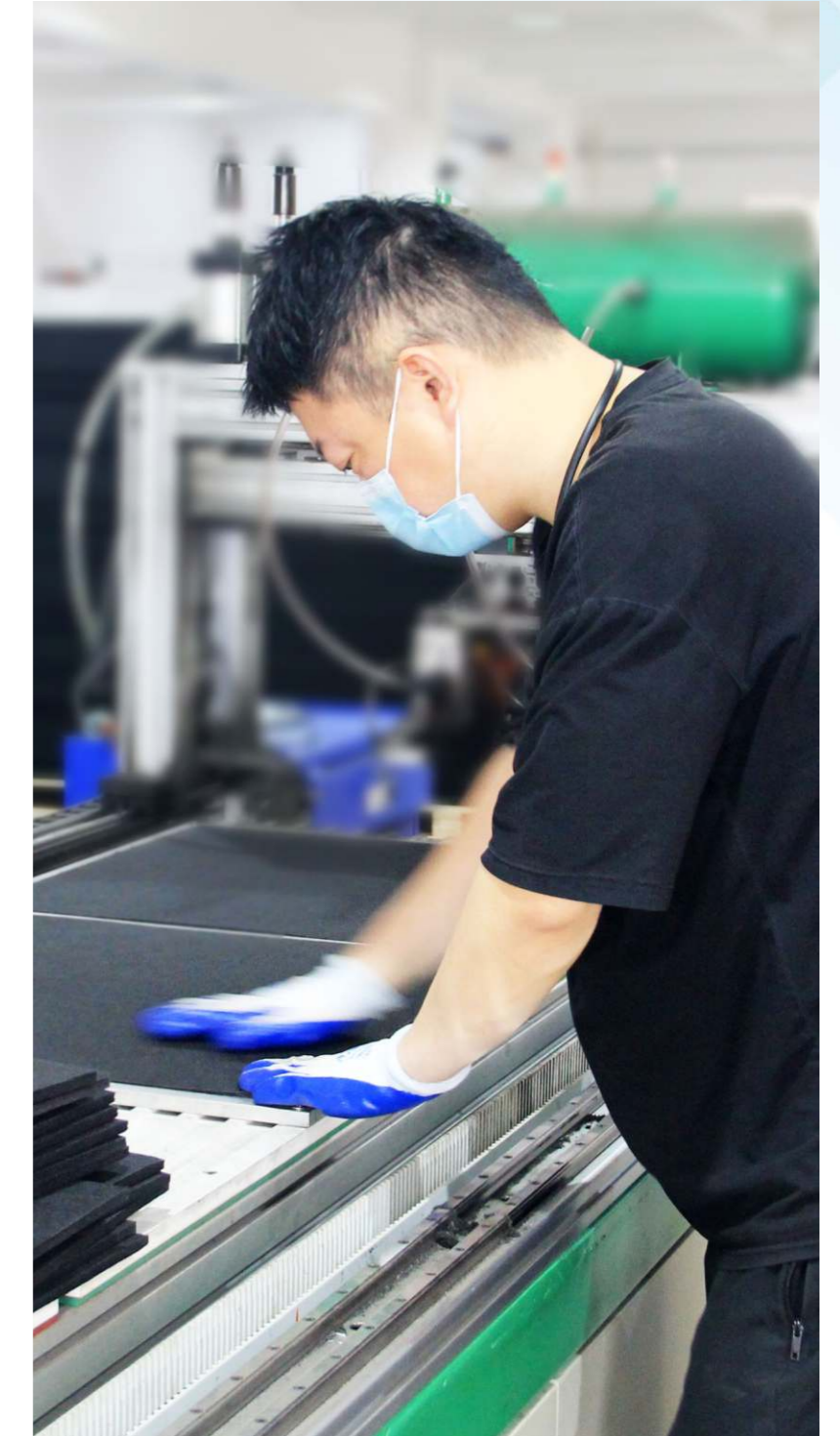

On-Line Inspection

ACOUSTIC PANEL PRODUCTION WORKSHOP



Polyester Fiber Acoustic Board Production Line Workshop



Equipment Operation



Finished Product



Corner Of the Workshop

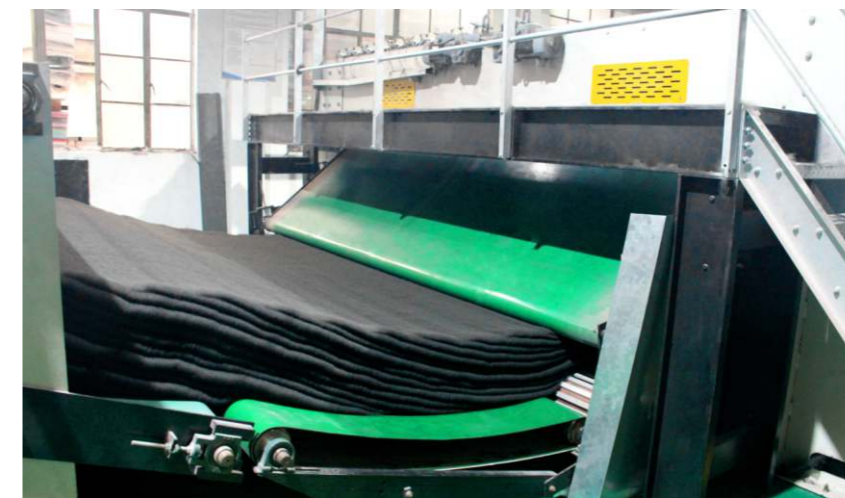

Equipment Operation



Production Line

PROCESSING EQUIPMENT



Laser Engraving Machine



CNC Vibration Engraving Machine

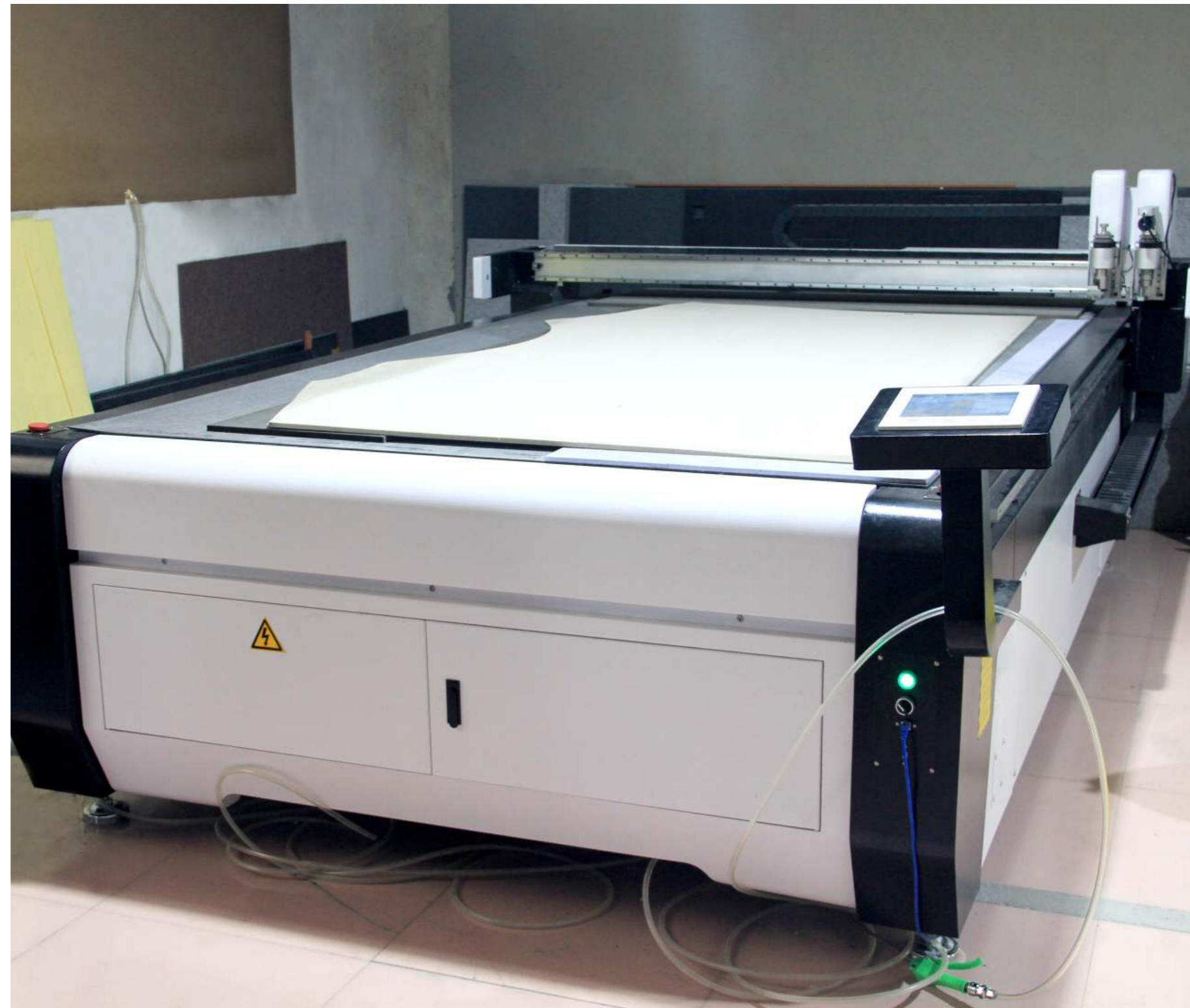

CNC Vibration Engraving Machine



CORNER OF THE WORKSHOP



Polyester Fiber Raw Material



Wood Wax Oil Coating Line



Cut the Density Board



Density Batten



Sample Cutting

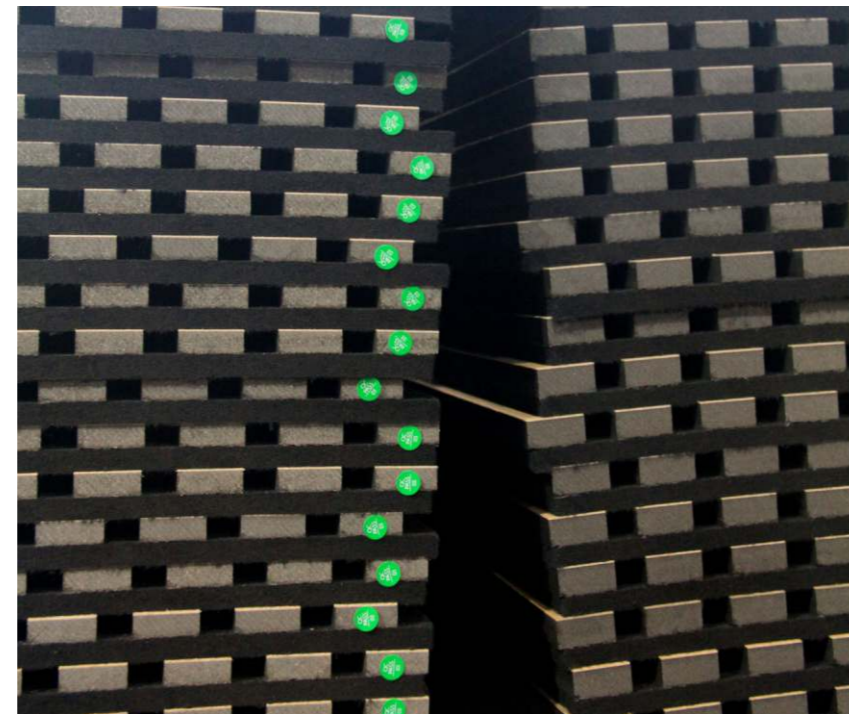

Qualified Product



Acoustic Slat Panel



Product Packaging

LABORATORY

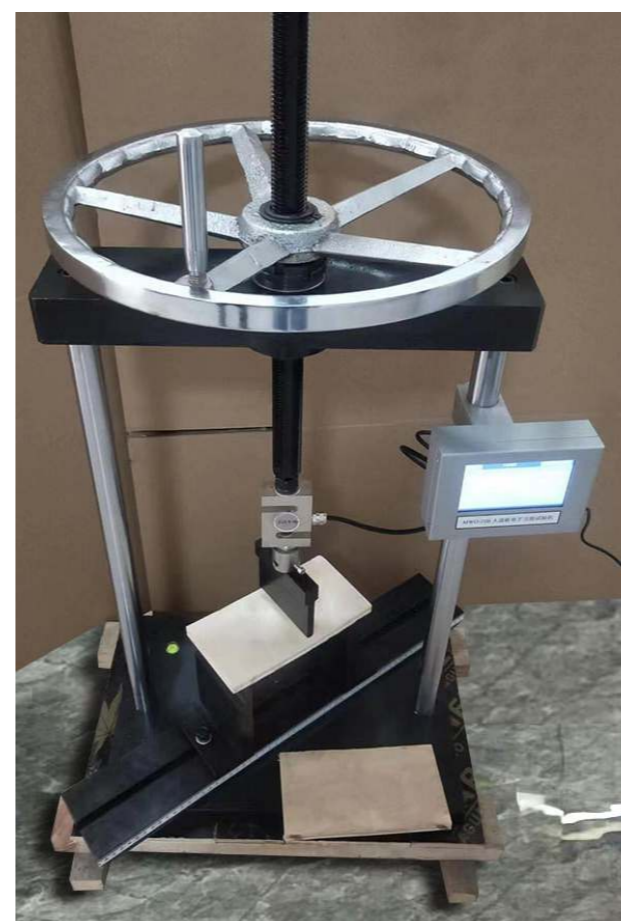

Laboratory

We are committed to fully meeting the expectations of our customers and all products are passed through a complete quality control system. In this regard, we have a complete set of experimental equipment for product quality and product characteristics. The purpose is only to give to the customer's hands Products are qualified and exceed customer expectations.

QUALITY CONTROL



On-Line Inspection

- ★ • Products are passed through a complete quality control system.
- ★ • Online with professional quality inspectors to track the whole production.
- ★ • Perfect and thoughtful after-sales team, if there are any defects, can quickly solve the problem.

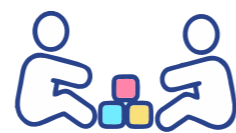

◀ PRODUCT CATEGORY ▶

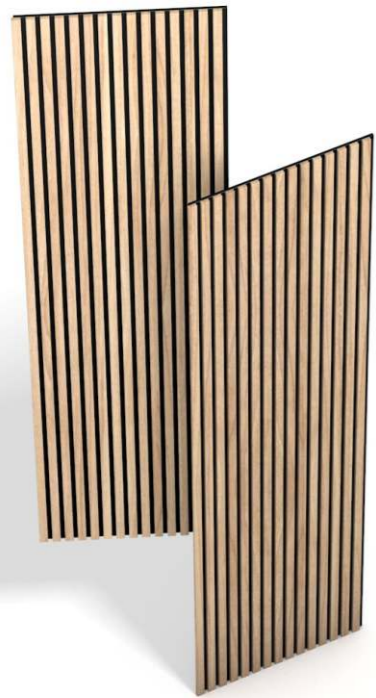

ACOUSTIC PANEL

- Standard polyester acoustic board
- Ceiling acoustic molding panel
- Polygonal shape acoustic board
- Pattern engraving board



ACOUSTIC FLOORING PRODUCTS

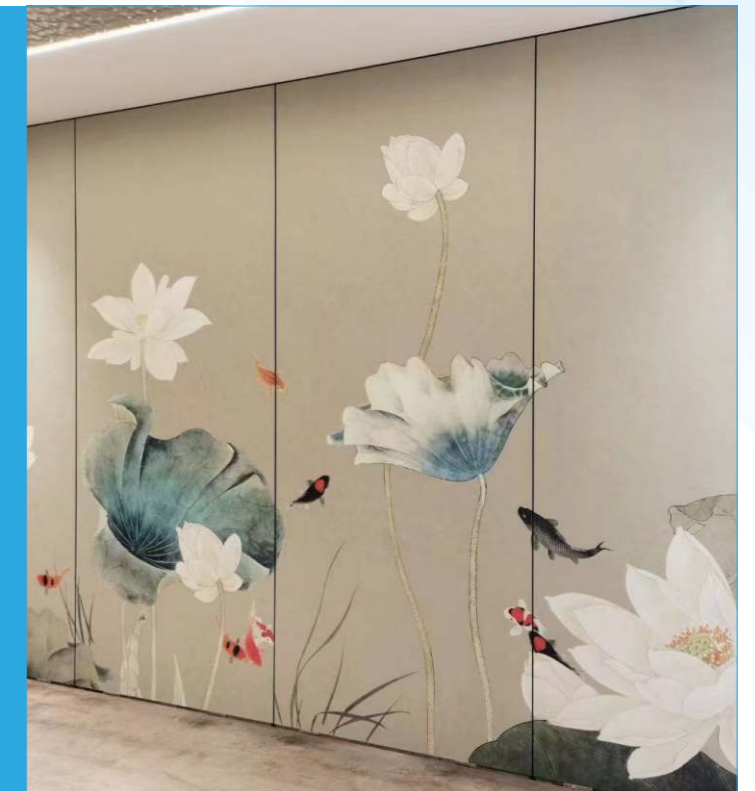

ACOUSTIC SLAT PANEL

- Wooden strip grating plate
- PET acoustic grille plate
- Acoustic grille panel combination



FREESTANDING WALL

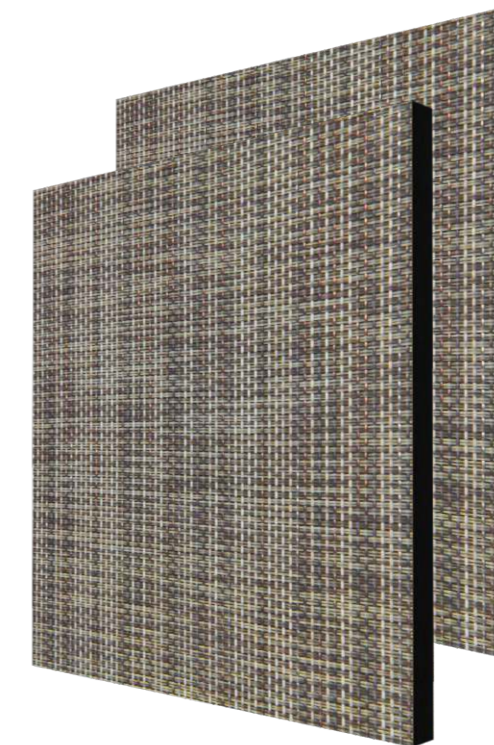

WALLBOARD



ACOUSTIC SLAT PANEL



Product introduction

Wood grating board is a kind of decorative material made of polyester fiber by hot pressing and coupled with wood grain and sound absorption function. Polyester fiber is made of high technology hot pressing and cocoon cotton shape to achieve density diversity to ensure ventilation, and become an excellent decorative product in sound absorption and heat insulation materials. The sound absorption coefficient reaches above 0.9 in the noise range of 125~4000HZ, shorten the adjustment of reverberation time according to different needs, remove sound impurities, improve sound effect and improve language clarity; The product has sound absorption, flame retardant, insulation, heat insulation, moisture-proof, mildew proof, easy to cut, no harm to the body and other remarkable characteristics, is the ideal choice for home decoration.

Polyester acoustic board
backing Class A fire rating It is
certified by ASTM E84-16

Product structure

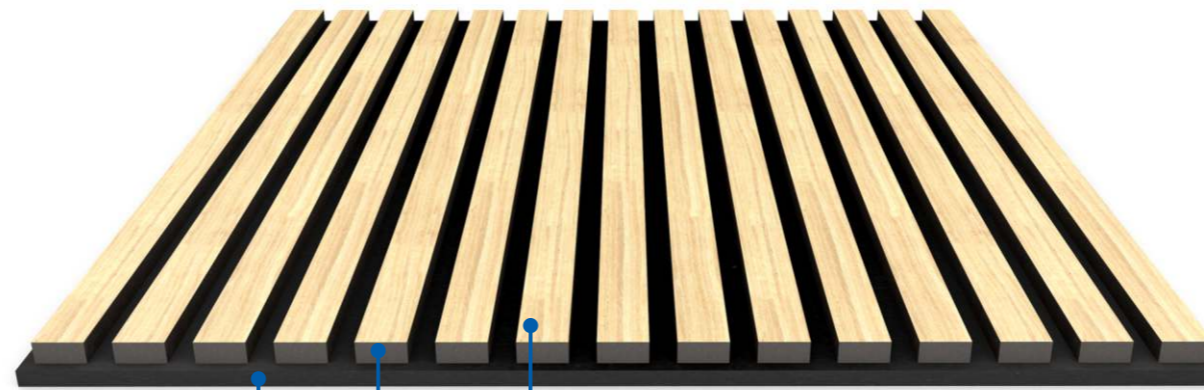

Wood grain surface

Medium density fiber wood strip

Acoustic Panel

The sound absorption coefficient of the sound absorption board

According to the test method of EN ISO 354:2003, laboratory measurements of the absorption coefficient were carried out in a reverberation chamber.

The grille is mounted directly on the wall

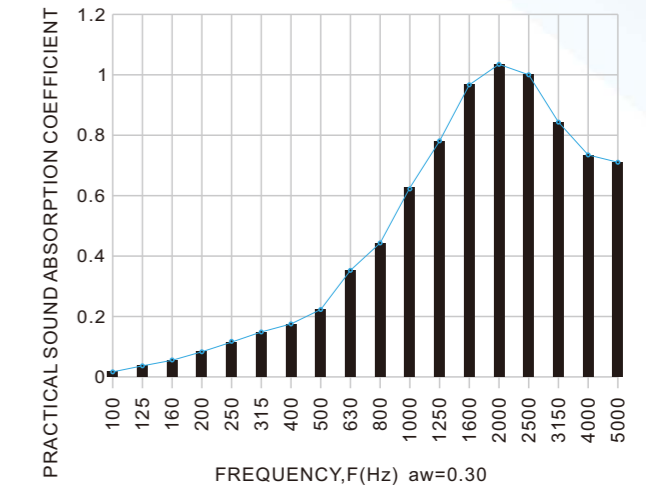

As shown in the figure, the 21mm panel, attached directly to the wall, obtains an absorption coefficient of 0.3 (MH).

The grille is mounted on the wooden keel

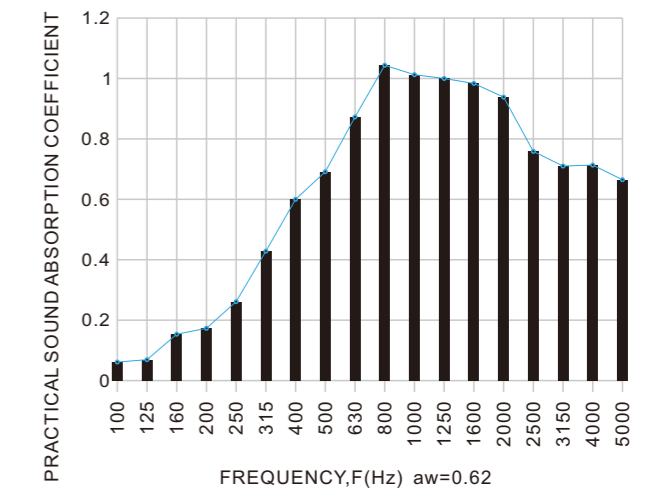

As shown, the 21mm panel, mounted on a 46mm spaced wood keel and mineral wool insulation, achieves an absorption coefficient of 0.62 (MH).

ACOUSTIC SLAT PANEL



A

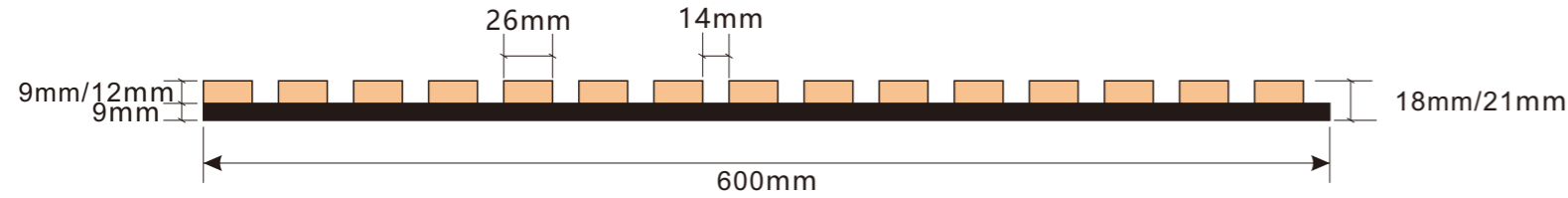

BASIC INFORMATION			
Product name		ACOUSTIC SLAT PANEL	
Sizes	Length	2400mm、2440mm、2750mm、3000mm Customizable	
	Width	600mm	
	Thickness	MDF	9mm、12mm
		PET	9mm
ACOUSTIC PANEL		600*2400*9mm--1 pcs	
Medium Density Fiber Board (MDF)		26*2400*12mm--15 pcs	
Grille Distance (MDF)		14mm	

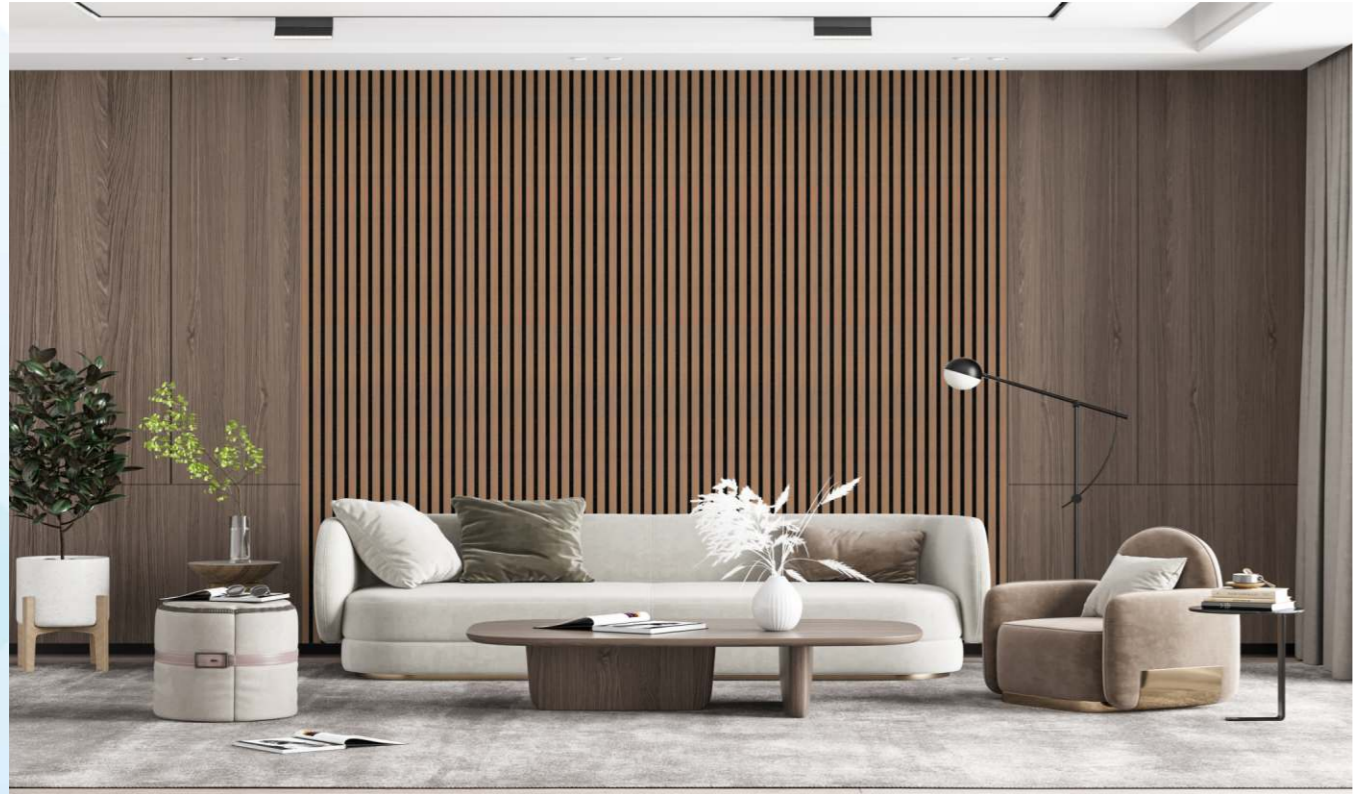

B

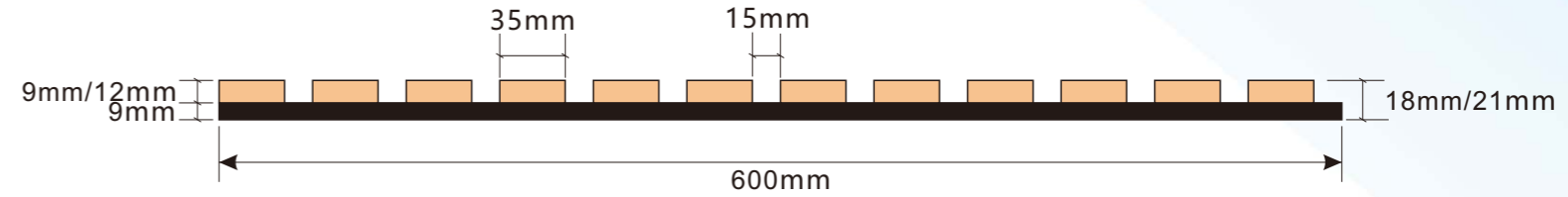

BASIC INFORMATION			
Product name		ACOUSTIC SLAT PANEL	
Sizes	Length	2400mm、2440mm、2750mm、3000mm Customizable	
	Width	600mm	
	Thickness	MDF	9mm、12mm
		PET	9mm
ACOUSTIC PANEL		600*2400*9mm--1 pcs	
Medium Density Fiber Board (MDF)		26*2400*12mm--12 pcs	
Grille Distance (MDF)		15mm	



ACOUSTIC SLAT PANEL 600x600mm

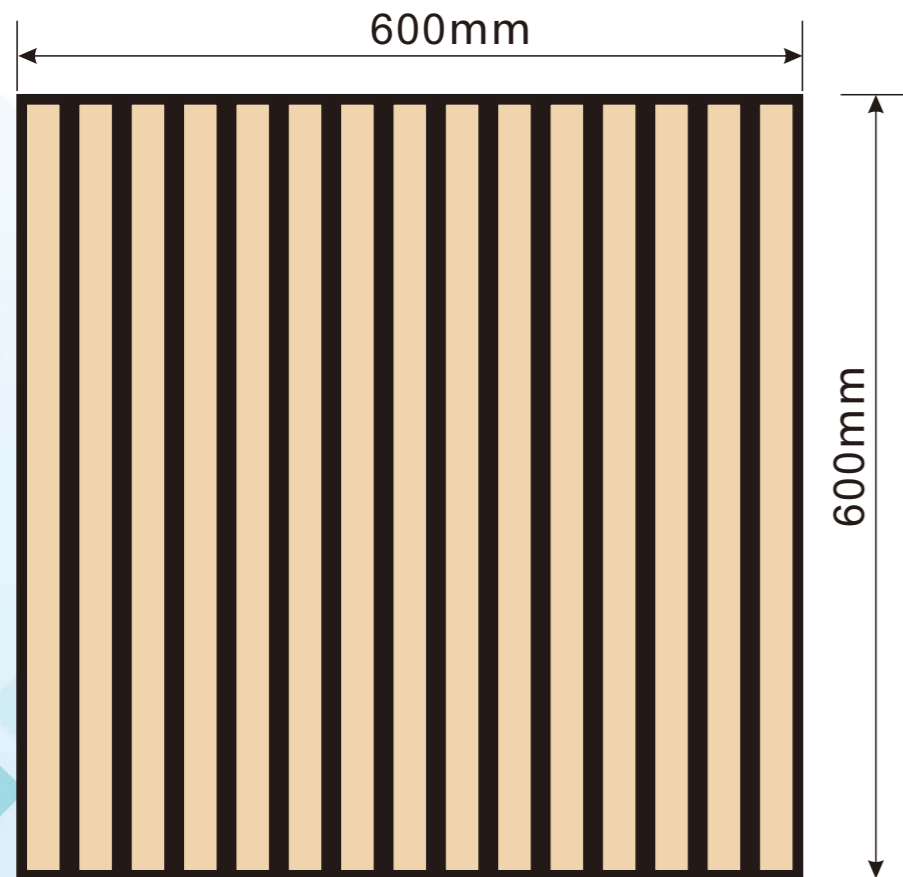
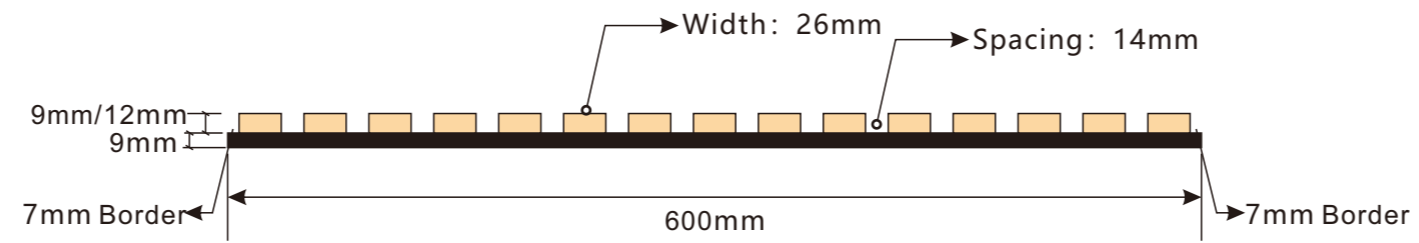
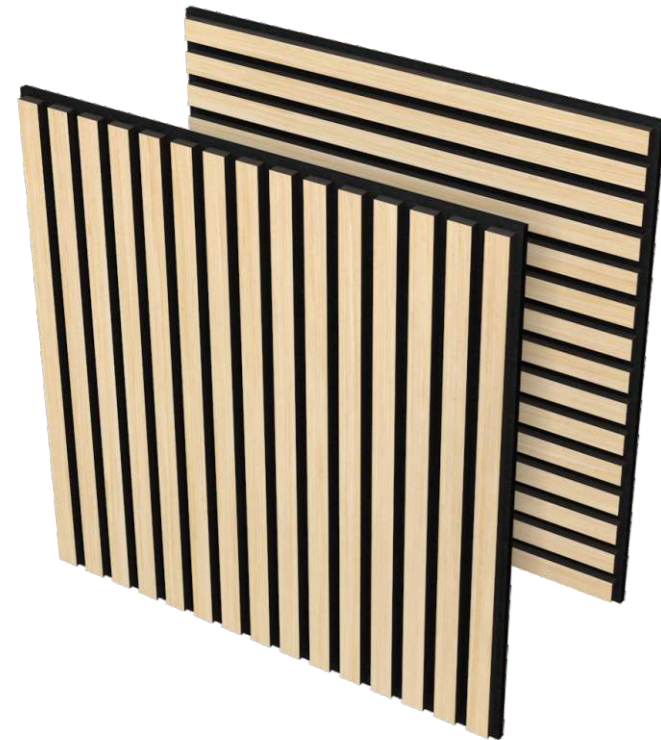

BASIC INFORMATION			
Product name		ACOUSTIC SLAT PANEL	
Sizes	Length	600mm	
	Width	600mm	
	Thickness	MDF	9mm、12mm
		PET	9mm
ACOUSTIC PANEL		600*600*9mm--1 pcs	
Medium Density Fiber Board (MDF)		26*600*12mm--15 pcs	
Grille Distance (MDF)		14mm	

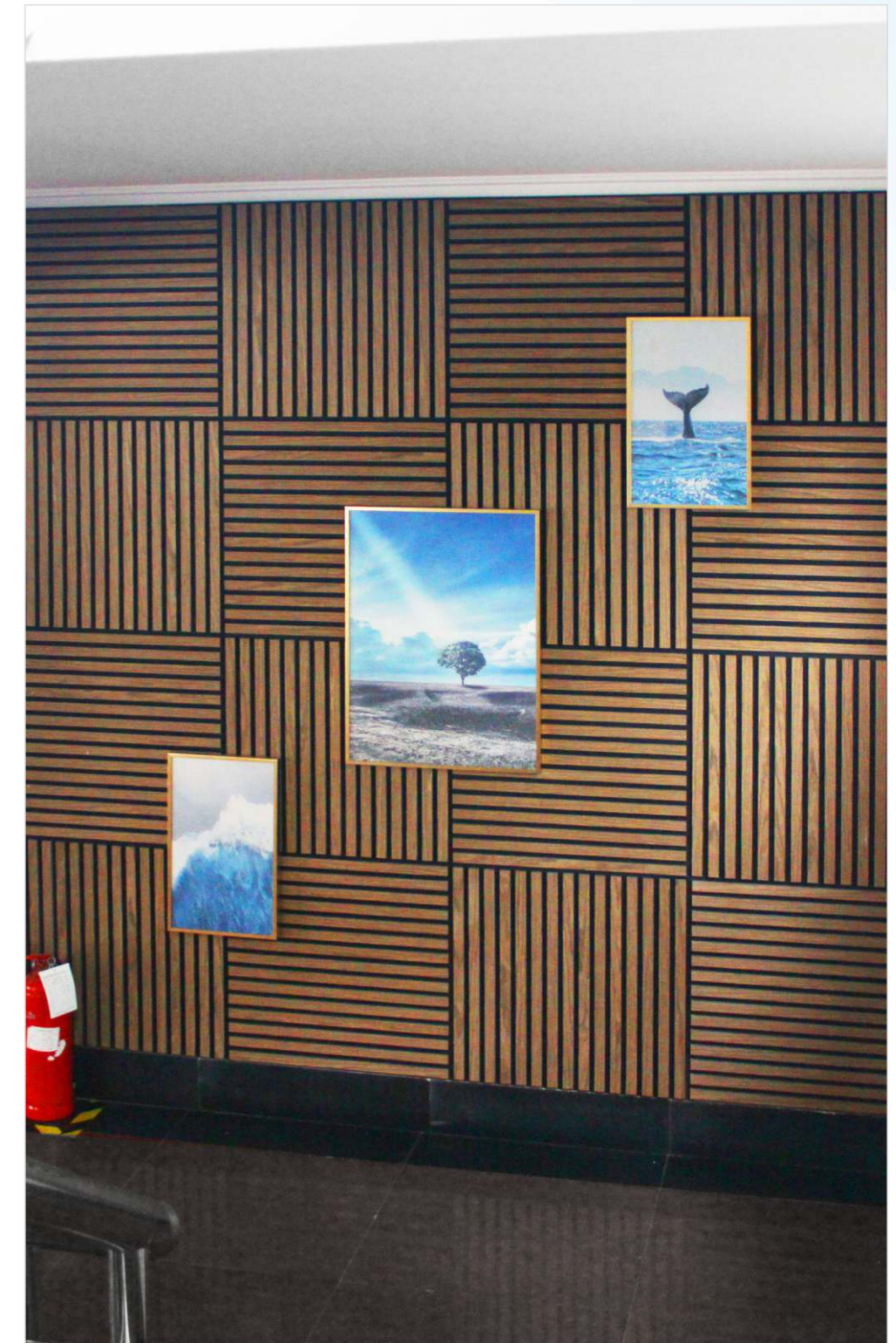
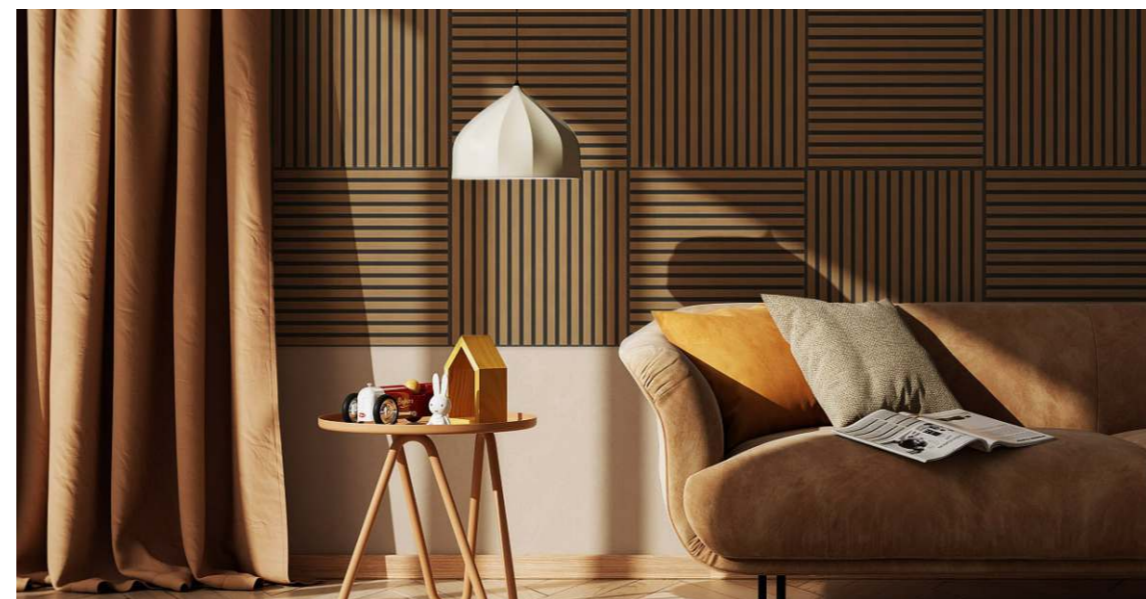

ACOUSTIC SLAT PANEL

Acoustic grille panel combination

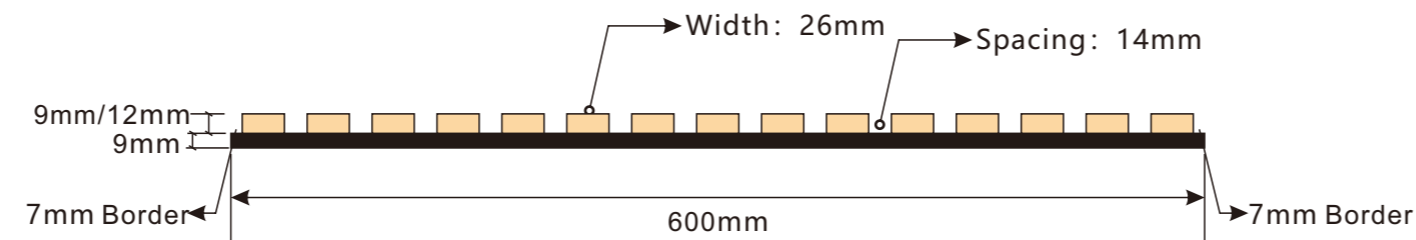
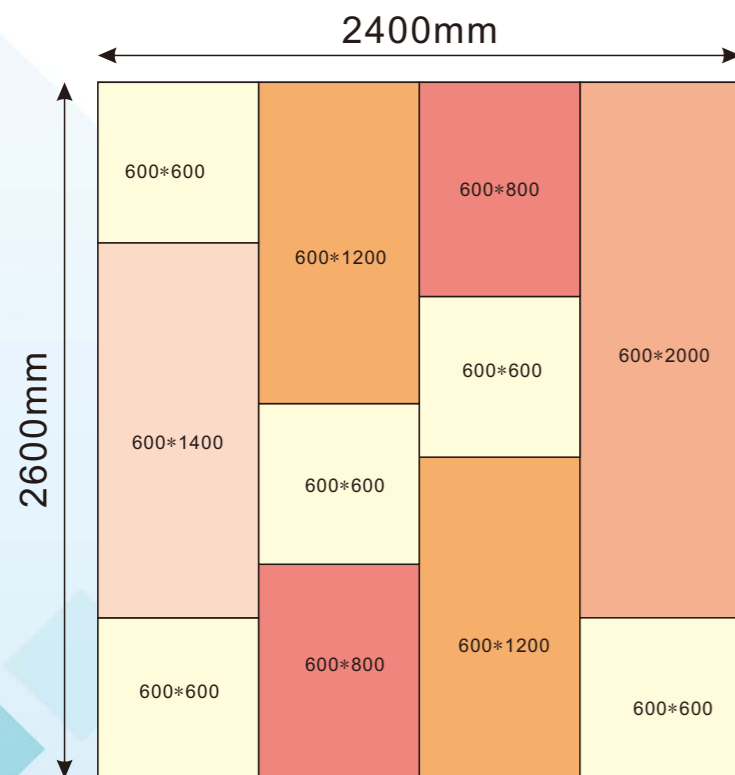
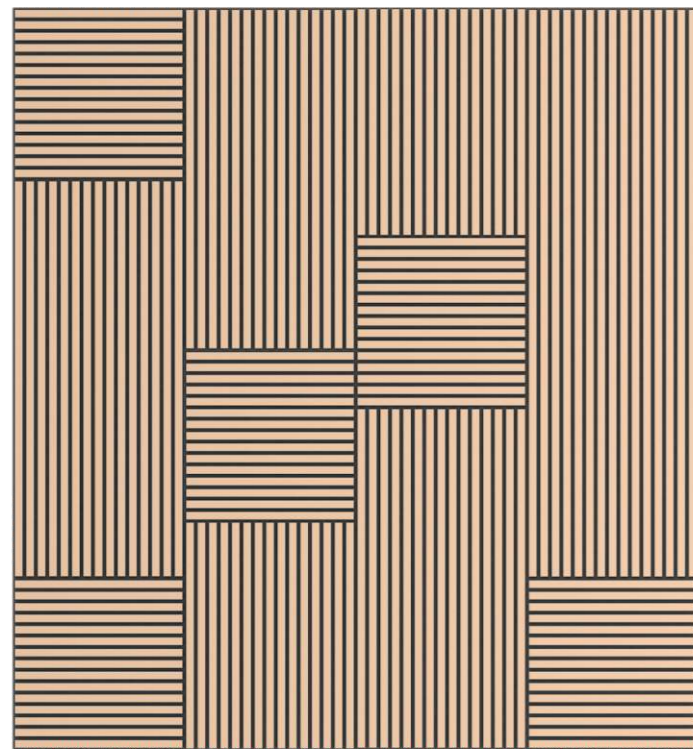

BASIC INFORMATION			
Product name		ACOUSTIC SLAT PANEL	
Sizes	Length	600mm	
	Width	600mm	
	Thickness	MDF	9mm、12mm
		PET	9mm
ACOUSTIC PANEL		600*600*9mm--1 pcs	
Medium Density Fiber Board (MDF)		26*600*12mm--15 pcs	
Grille Distance (MDF)		14mm	
Specification		Quantity	
600*600mm		5pcs	
600*1200mm		2pcs	
600*800mm		2pcs	
600*1400mm		1pcs	
600*2000mm		1pcs	

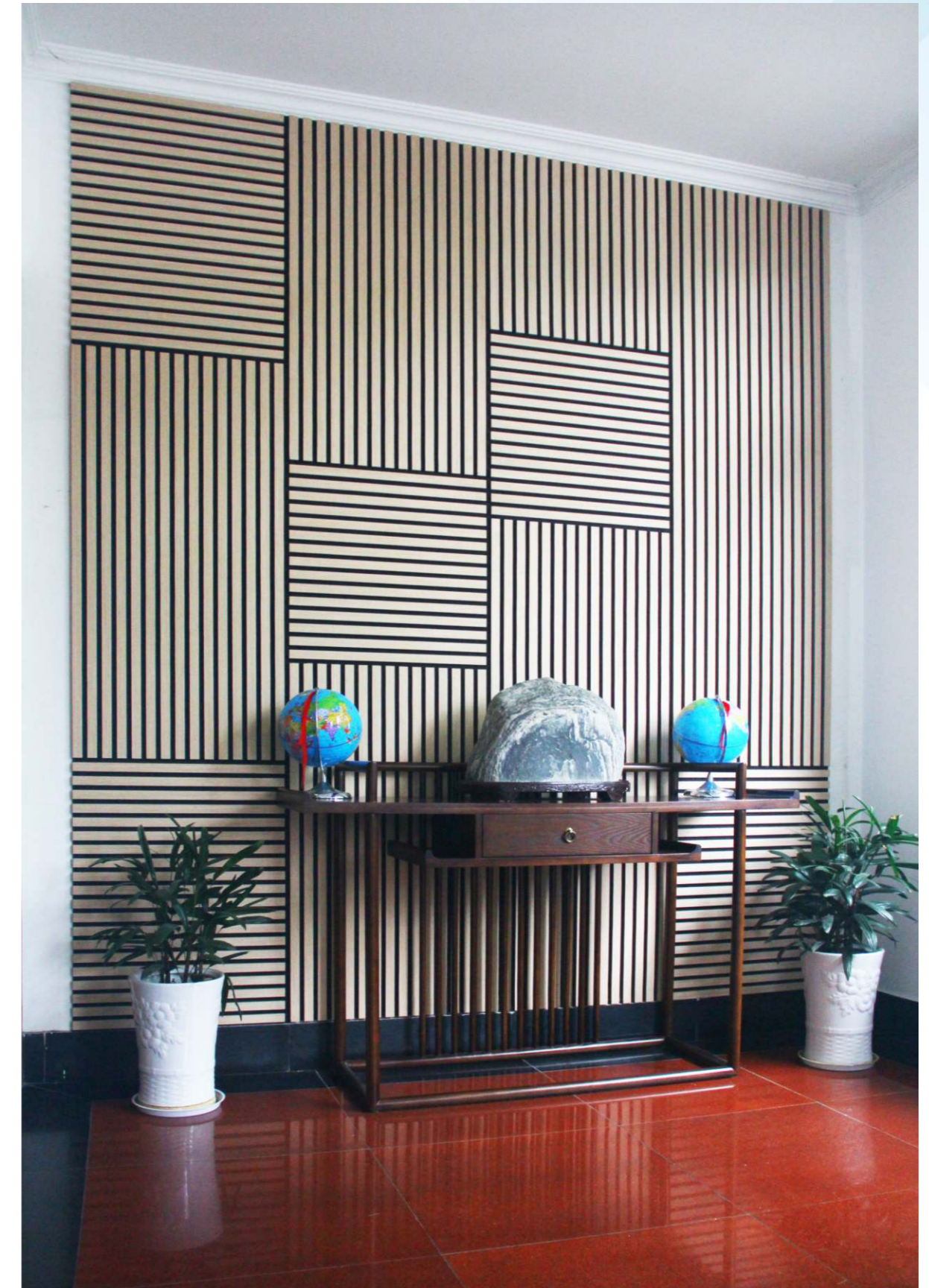



					
2# Washed Oak	3# Teak	4# Walnut	5# Smoked oak	6# Teak	7# Wenge
					
8# Siner Oak	9# Black Oak	10# Oak	11# Black Walnut	12# Teak	13# classic oak
					
14# Light Oak	15# Grey Oak	16# Oiled Oak	17# Deep Dark	18# -B2994	19# black oak
			<h1>COLOR</h1>		
UV-Black	UV-Grey	UV-White			

PET-ACOUSTIC SLAT PANEL

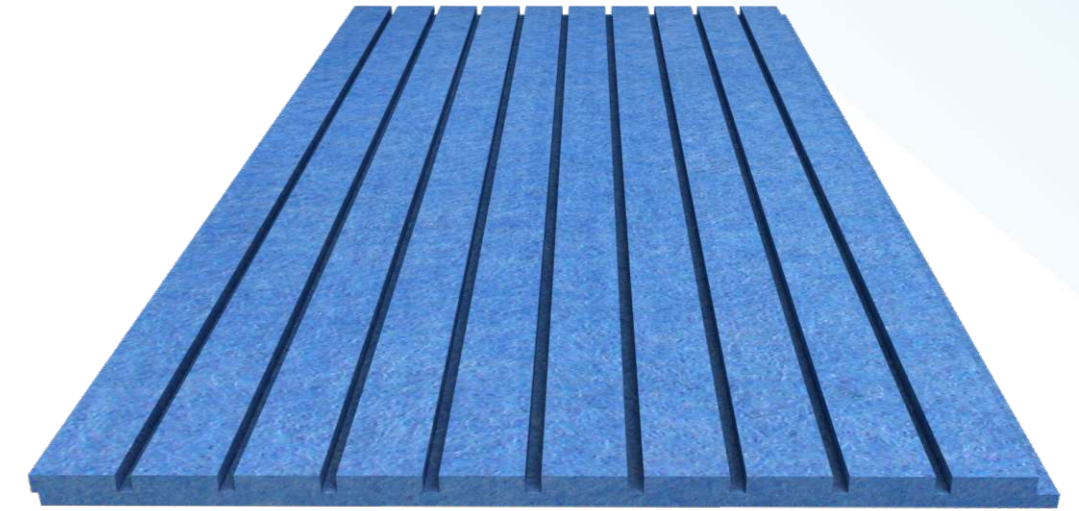
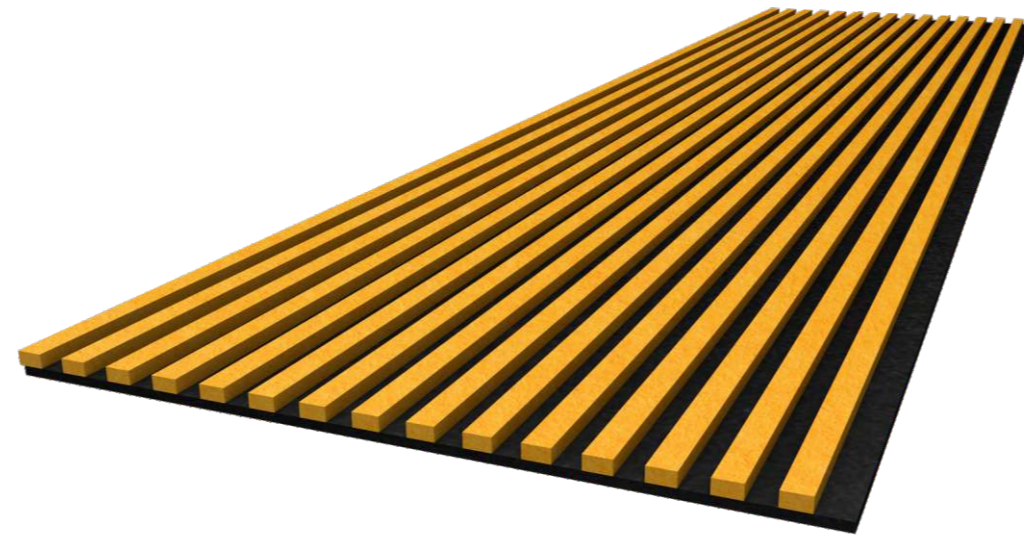
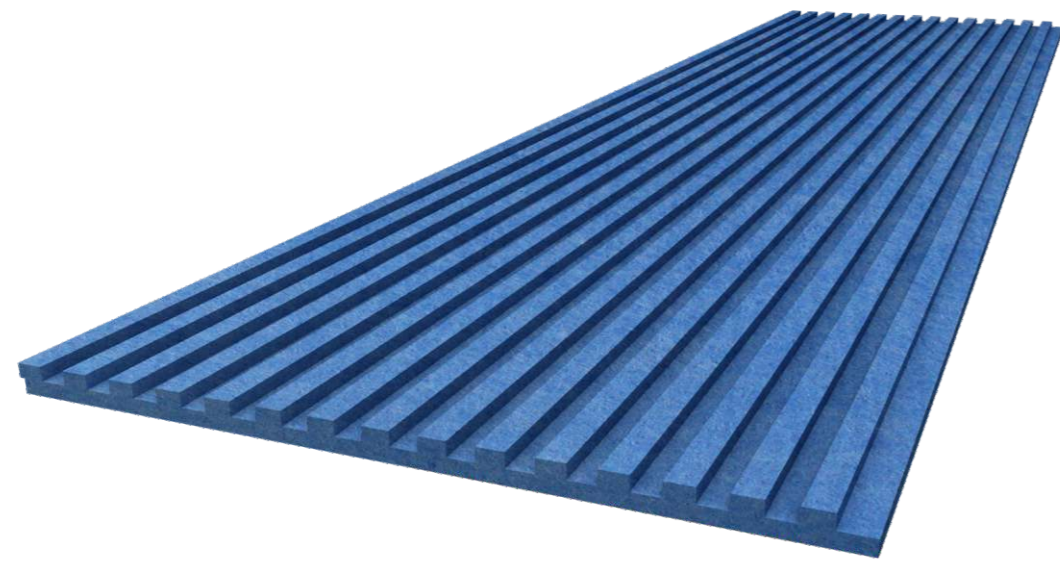

Product structure

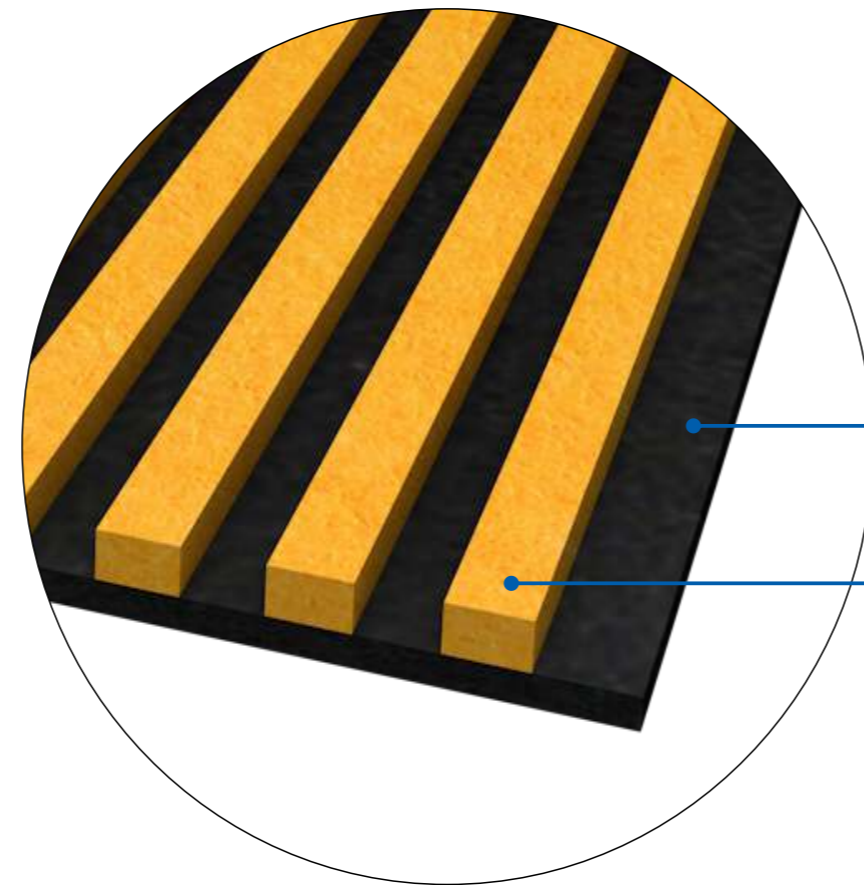

Acoustic Panel
Acoustic Panel

PET-ACOUSTIC SLAT PANEL

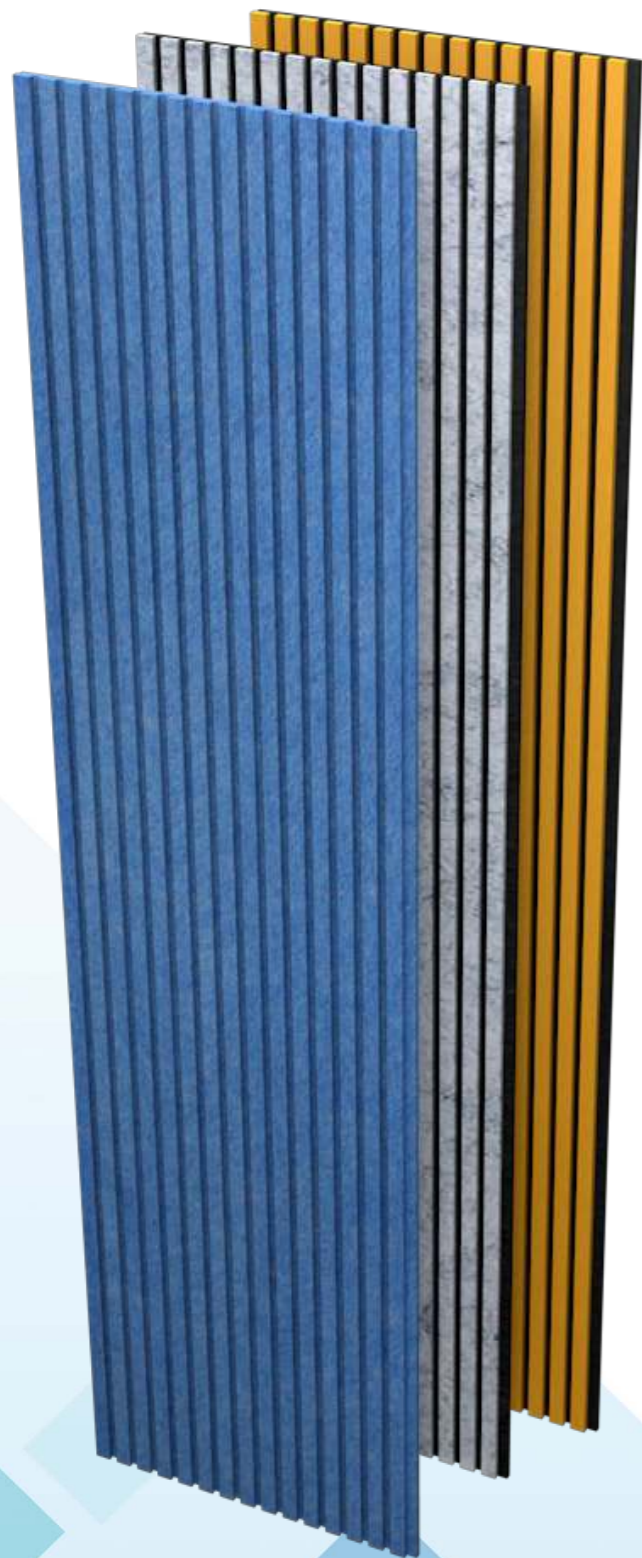

A

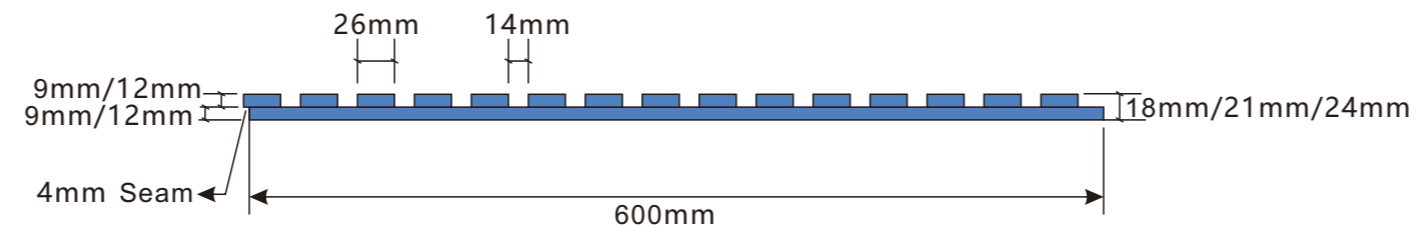

BASIC INFORMATION			
		Product name	ACOUSTIC SLAT PANEL
Sizes	Length		2400mm Customizable
	Width		600mm
	Thickness	Polyester fiber strip	9mm, 12mm
Acoustic Panel		9mm	

B

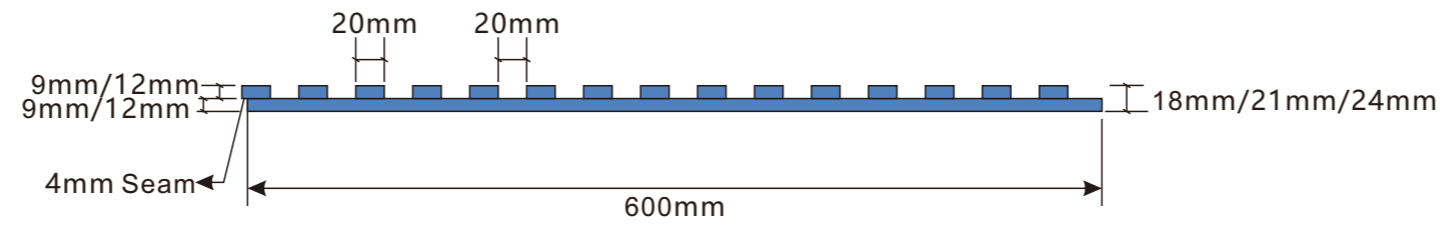

BASIC INFORMATION			
		Product name	ACOUSTIC SLAT PANEL
Sizes	Length		2400mm Customizable
	Width		600mm
	Thickness	Polyester fiber strip	9mm, 12mm
Acoustic Panel		9mm	

C

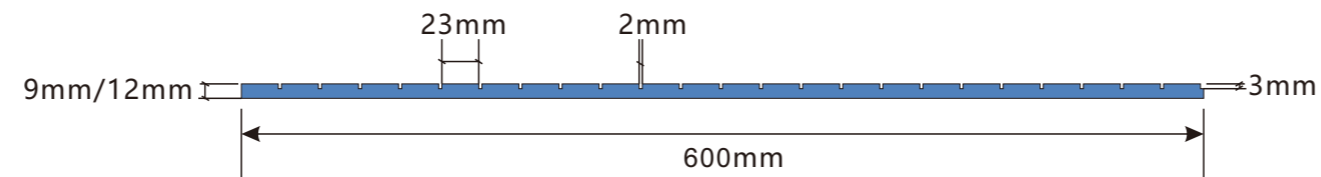

BASIC INFORMATION			
		Product name	ACOUSTIC SLAT PANEL
Sizes	Length		2400mm Customizable
	Width		600mm
	Thickness	Acoustic Panel	9mm, 12mm

PET-ACOUSTIC SLAT PANEL

PET-10mm

D

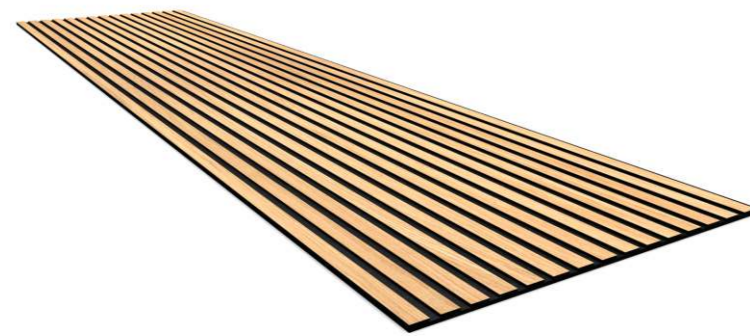

BASIC INFORMATION			
Product name		ACOUSTIC SLAT PANEL	
Sizes	Length		2400mm Customizable
	Width		600mm
	Thickness	MDF	1mm
		PET	9mm
Groove thickness		5mm	
ACOUSTIC PANEL		600*2400*9mm--1 pcs	
Wood veneer		26*2400*1mm--15 pcs	
Slot spacing		14mm	

E

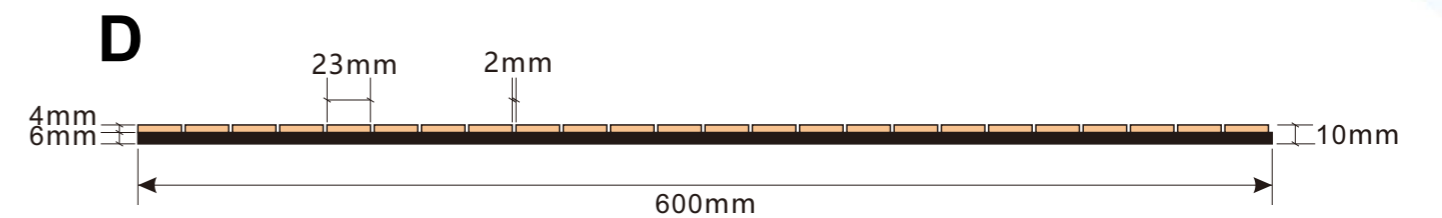

BASIC INFORMATION			
Product name		ACOUSTIC SLAT PANEL	
Sizes	Length		2400mm Customizable
	Width		600mm
	Thickness	MDF	4mm
		PET	6mm
Groove thickness		10mm	
ACOUSTIC PANEL		600*2400*6mm--1 pcs	
Wood veneer		23*2400*4mm--24 pcs	
Slot spacing		2mm	

PET COLOR

MONOCHROME



DUAL COLOR SERIES

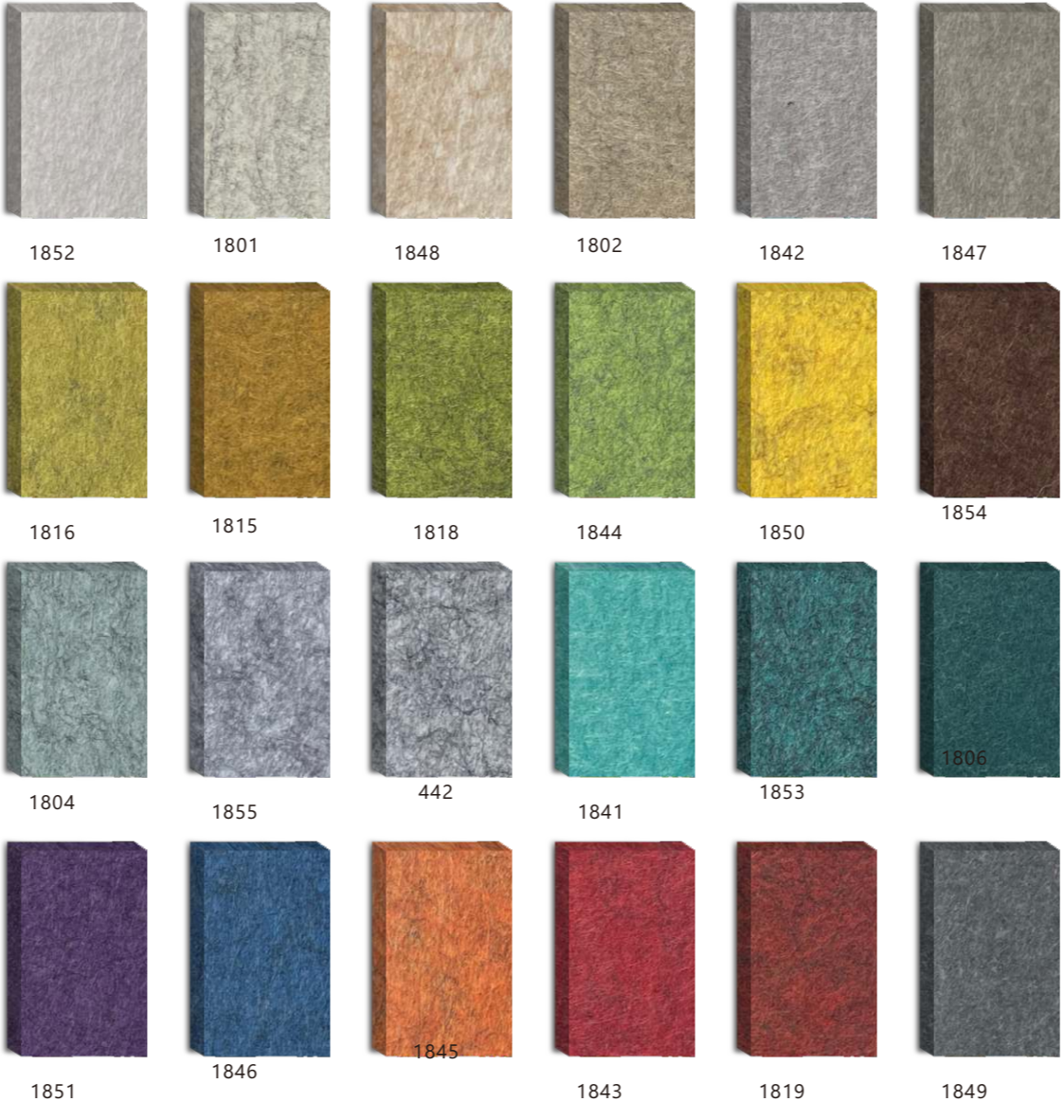

FLAME RETARDANT



Display colors are all regular colors,
For custom colors, please provide samples!

ACOUSTIC PANEL

Product introduction



The full name of the sound absorbing board is polyester fiber decorative sound absorbing board. The raw material is polyester fiber hot pressed by the equipment, the product has high strength, and the cocoon-shaped cotton made by a unique technology to achieve density diversification and ensure certain ventilation performance. So that the product has a good sound absorption effect and heat insulation performance. The sound absorbing board can shorten and adjust the reverberation time to adapt to different needs, remove sound impurities, improve sound and improve voice clarity. Study on sound absorption properties of polyester fiber and other porous materials similar. The absorption coefficient increases with frequency as the sound increases. The high frequency absorption coefficient is very large. Sound absorption performance, noise reduction coefficient is about 0.8~1.1, is one efficient sound absorption product. Polyester fiber sound-absorbing board has super sound insulation performance, because its material characteristics are uniform and strong, so it has decoration, heat preservation, fire retardant, light body, easy processing, good stability, impact resistance, wear resistance, easy maintenance, good elasticity, toughness, tear resistance, not easy to damage and other characteristics.

Product specification

Materials	100% high quality polyester fiber soundproof board
Sizes	1220*2440mm Customizable
Thickness	9mm/12mm/24mm
Fire rating	B1
Environmental grade	E0
Authentication sound absorption parameters	0.8-1.1
color	White, blue, green, yellow, etc. (Color card 44 colors)

ACOUSTIC PANEL

Ceiling acoustic molding panel

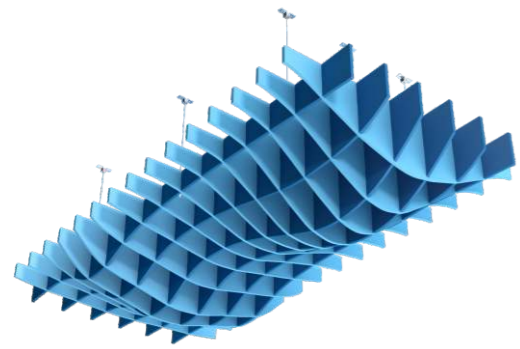

0A-220801

BASIC INFORMATION			
Product name		ACOUSTIC PANEL	
Sizes	Molding size	1200*2400*400mm	
	Thickness	PET	9mm、12mm

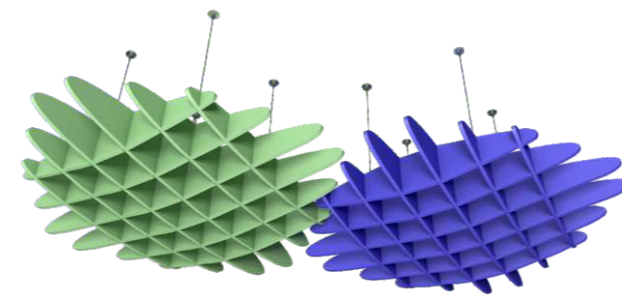

0A-220803

BASIC INFORMATION			
Product name		ACOUSTIC PANEL	
Sizes	Molding size	1200*1200*180mm	
	Thickness	PET	9mm、12mm

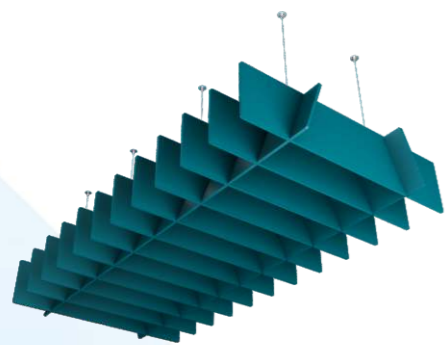

0A-220802

BASIC INFORMATION			
Product name		ACOUSTIC PANEL	
Sizes	Molding size	1180*2400*277mm	
	Thickness	PET	9mm、12mm

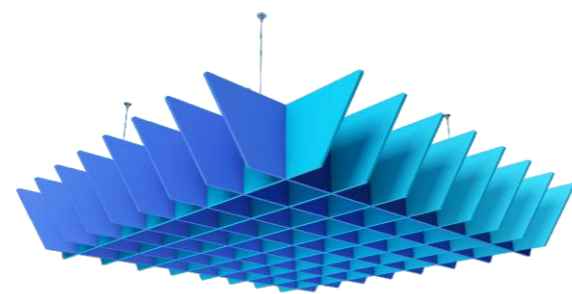

0A-220804

BASIC INFORMATION			
Product name		ACOUSTIC PANEL	
Sizes	Molding size	1200*2400*290mm 2400*2400*290mm	
	Thickness	PET	9mm、12mm

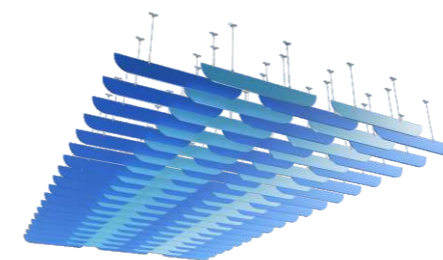

0A-220812

BASIC INFORMATION			
Product name		ACOUSTIC PANEL	
Sizes	Molding size	1200*200mm/1pcs	
	Thickness	PET	9mm、12mm



ACOUSTIC PANEL

Hexagonal sound-absorbing panel

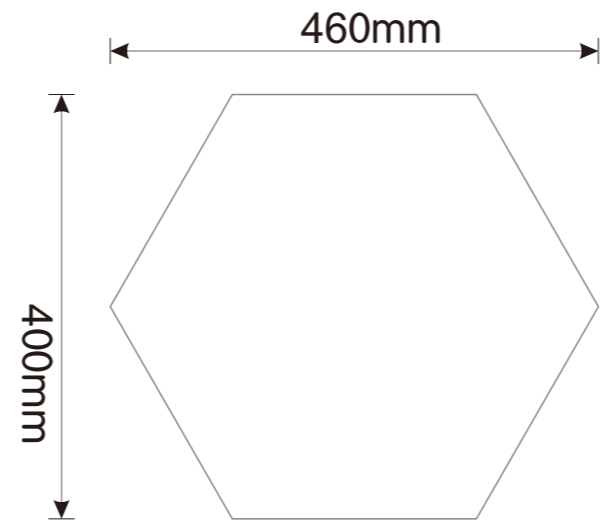
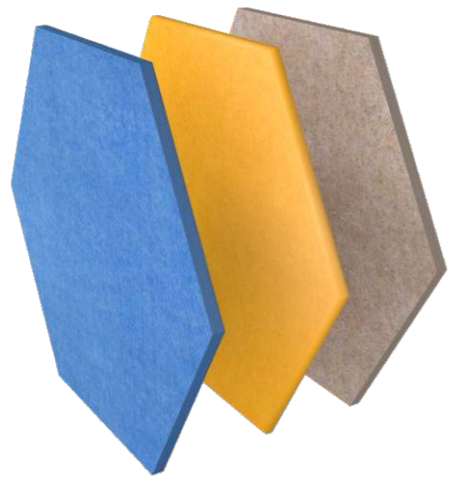

TH-002

BASIC INFORMATION			
Product name		ACOUSTIC PANEL	
Sizes	Molding size	460*400mm	
	Thickness	PET	9mm、12mm

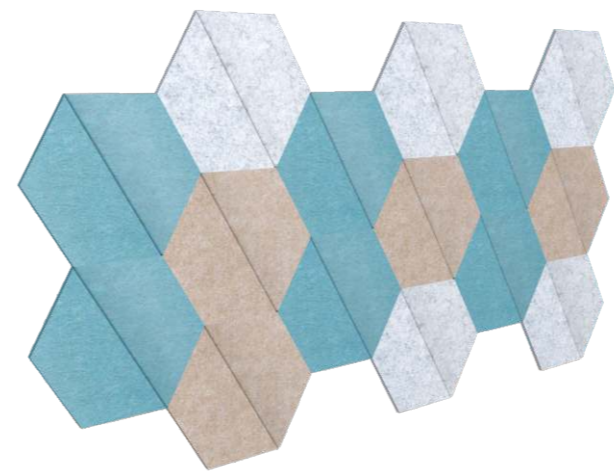

MULTIPLE STYLES

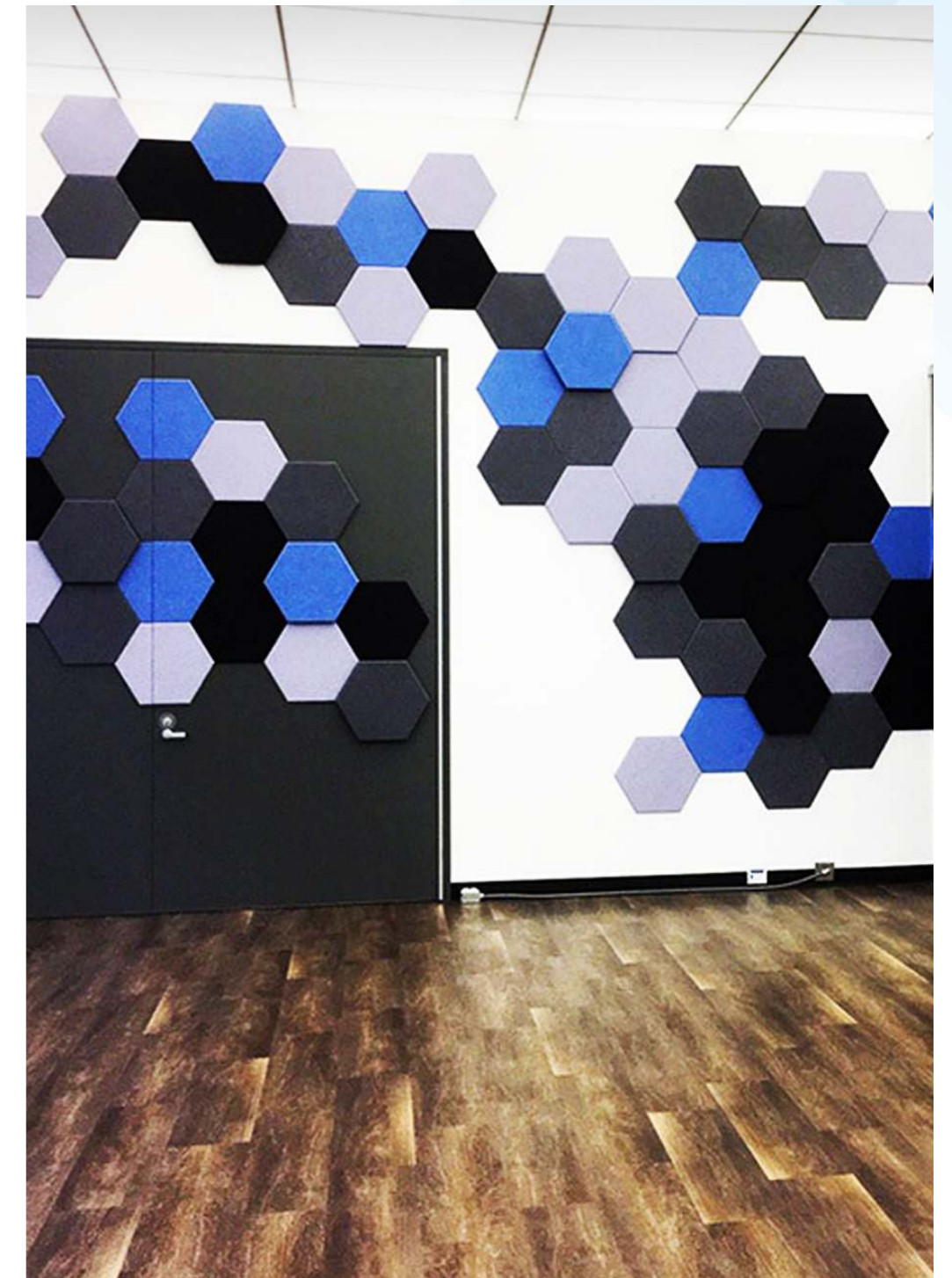
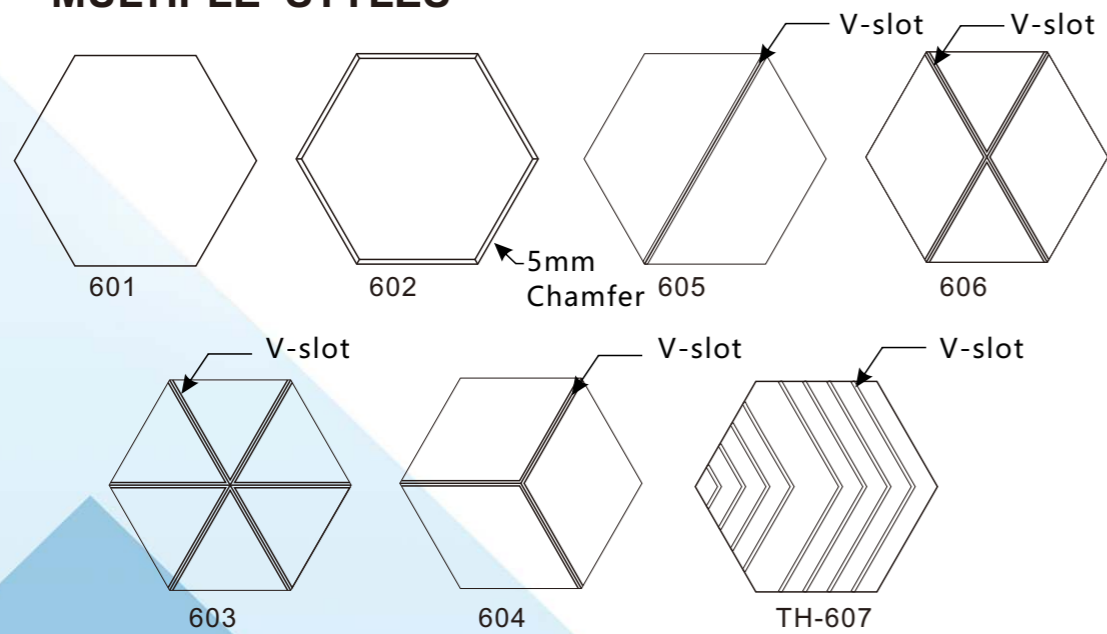

ACOUSTIC PANEL

Square sound-absorbing board

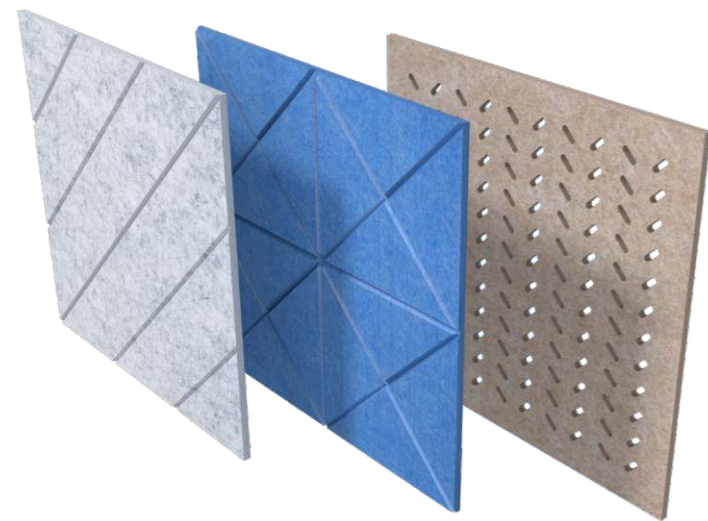

TH-003

BASIC INFORMATION			
Product name		ACOUSTIC PANEL	
Sizes	Molding size		400*400mm 600*600mm Customizable
	Thickness	PET	9mm, 12mm

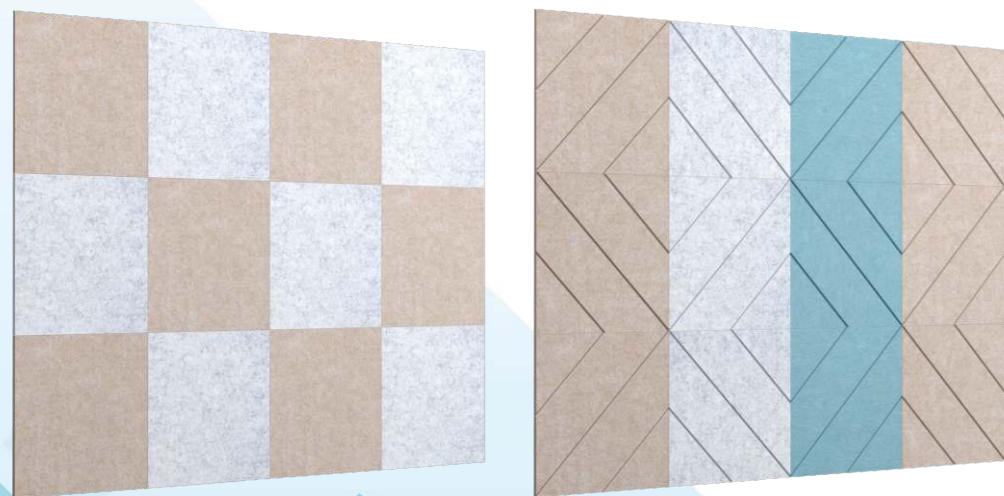

MULTIPLE STYLES

5mm Chamfer

401 402 403 404 405 406 407 408 409 410 411

Red line: Slot V

412 413 414 415 416 417 418 419 420 421 422 423

Carve out

ACOUSTIC PANEL

Screen sound-absorbing panel

Product specifications: 12mm thick support customization

A

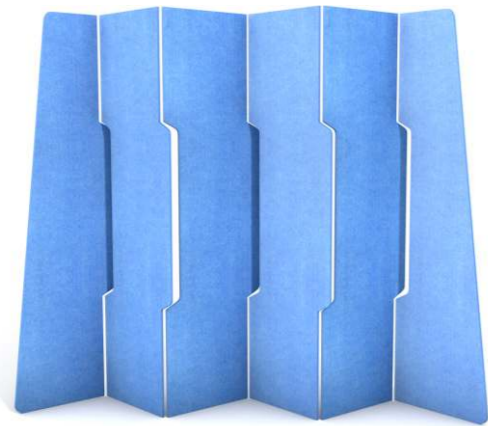

Front view

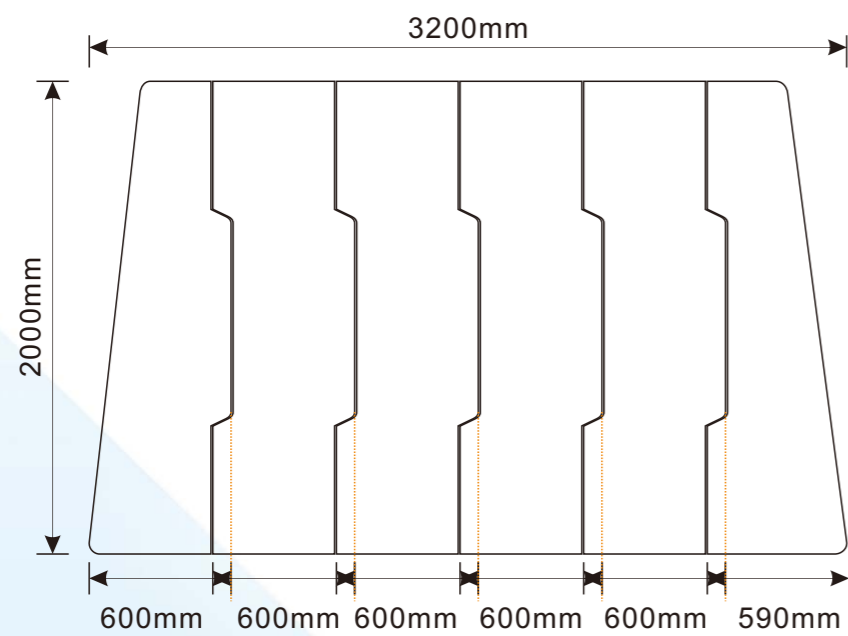

Top view

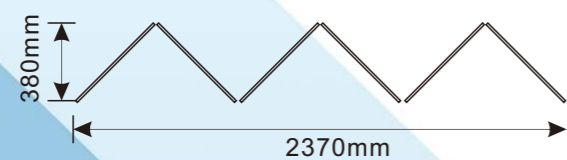

B



Front view

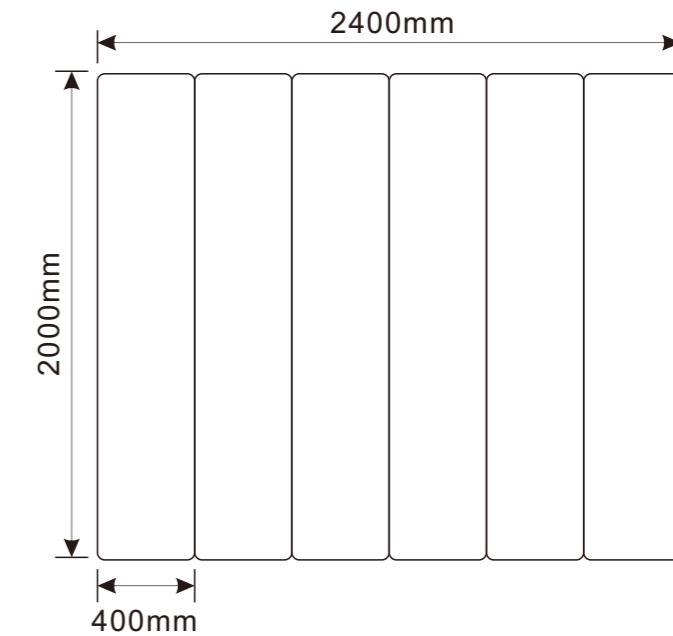

Top view

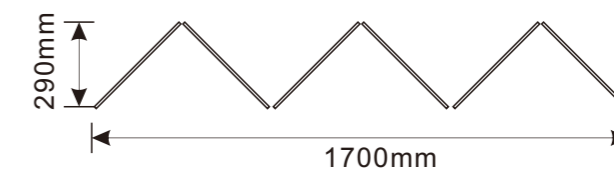

ACOUSTIC PANEL

Pattern engraving board

BASIC INFORMATION

Product name: ACOUSTIC PANEL
Pattern engraving board
Finished size: 600*1200mm
1200*2400mm
Thickness: 9mm, 12mm
Customizable

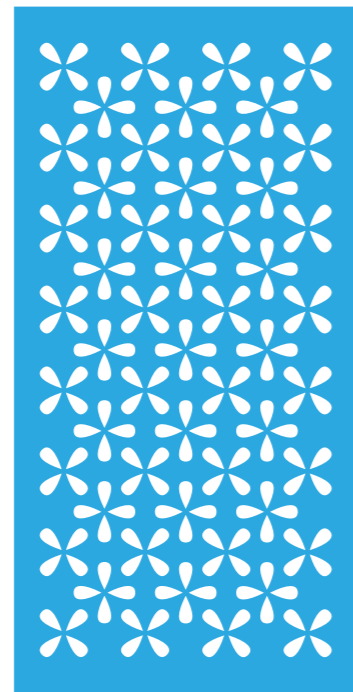

001

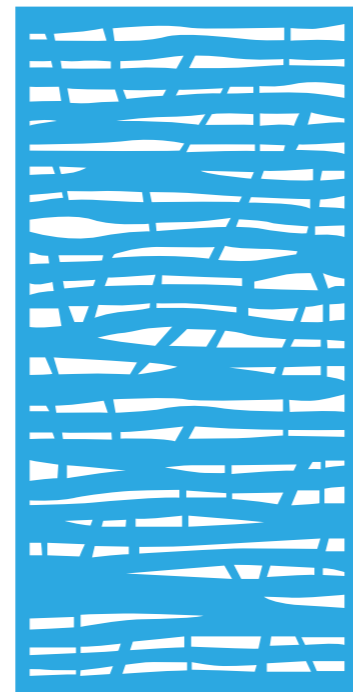

002



003



004



T005



006

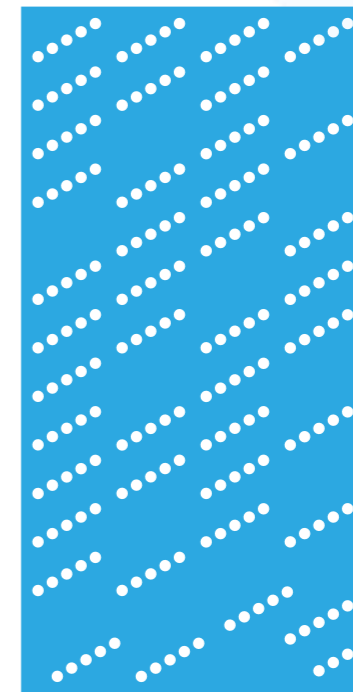

007



008



009



010

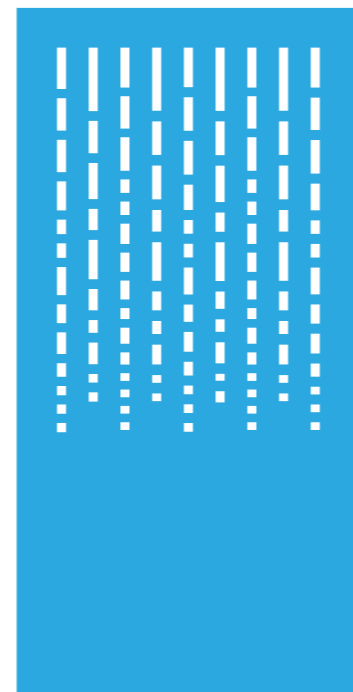

011



012



013

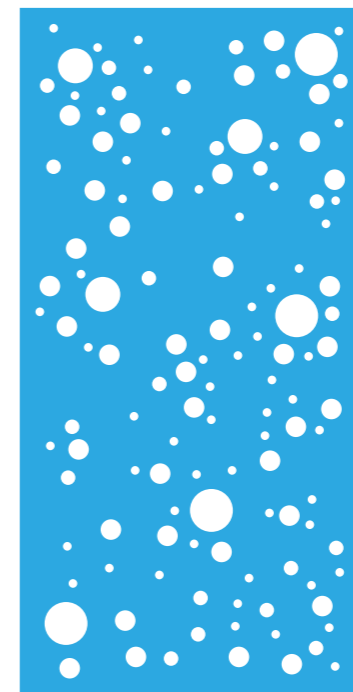

014



015

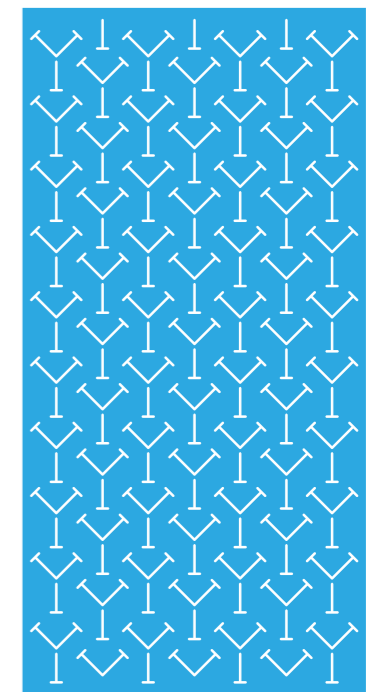

016

SCREEN GRILLE PRODUCTS

Product introduction



Length: 1300mm
Width: 1300mm
Thickness: 40mm

Product structure

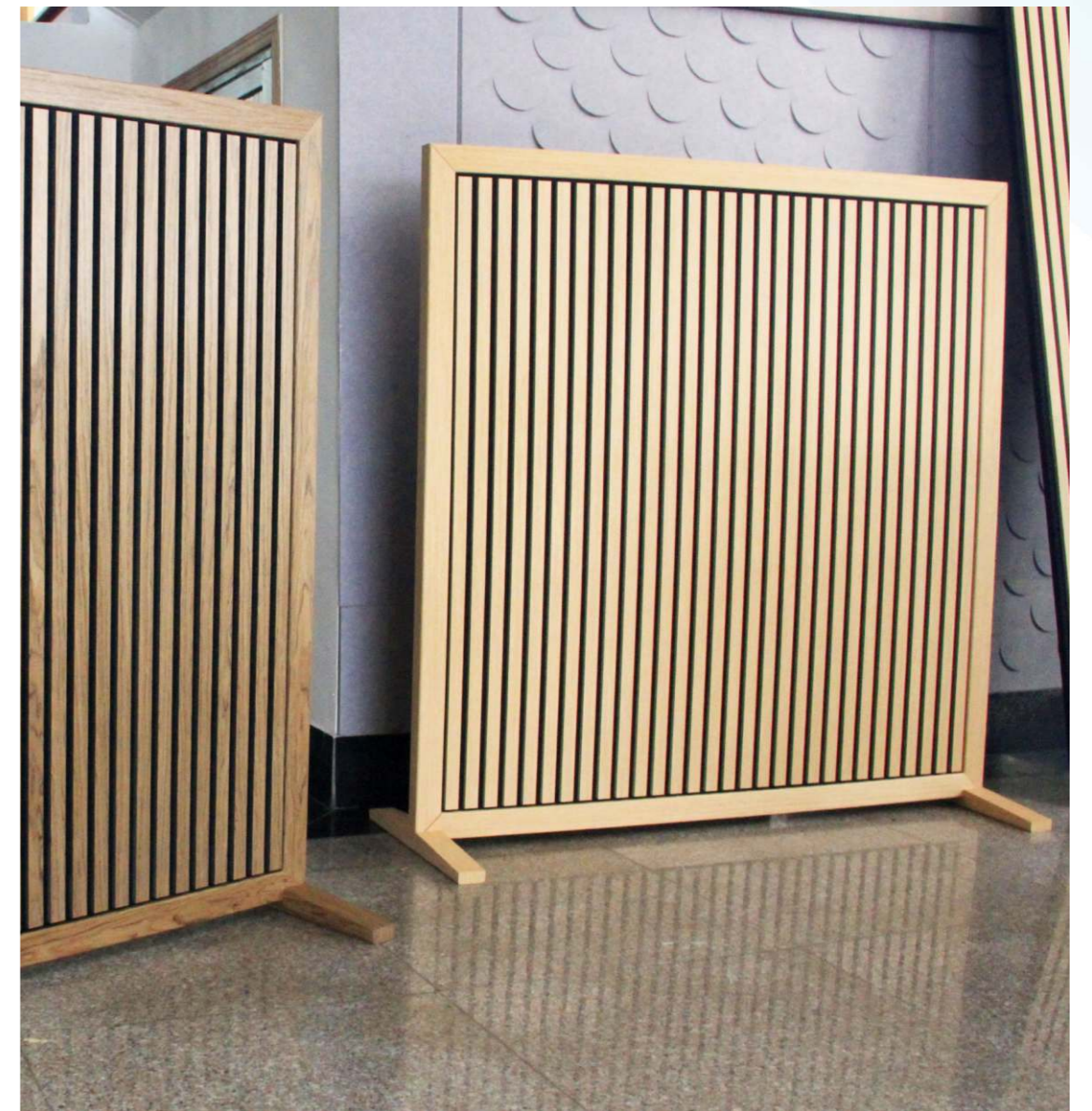
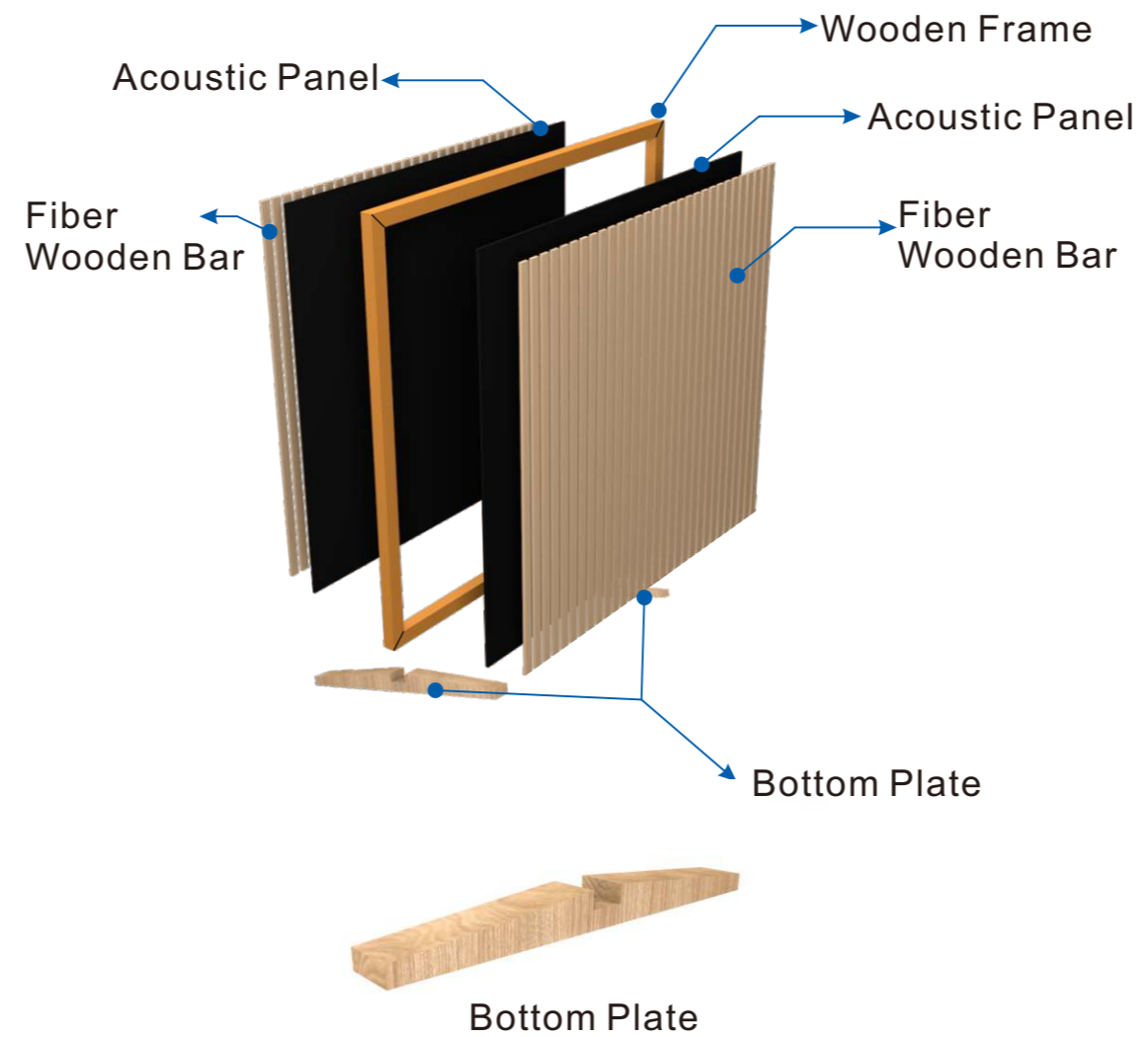

ACOUSTIC FLOORING PRODUCTS

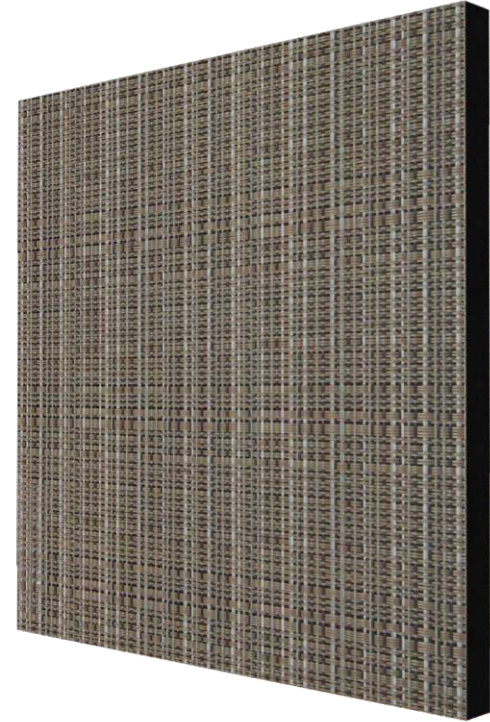

Product introduction

The Tianhan woven flooring collection combines Tianhan's expertise with the designer's contemporary vision. The fresh perspective and unique identity cultivated by the studio are cleverly expressed in the floor's eight collections. The rich textures are inspired by nature, the elegant subtle and complex colors reveal the aesthetics of our raw materials, and the quality confirms the viability of the floor collection. It's delicate and neutral in deep, delicate tones. Bold colors add infinite personality, while graphic variety of effects, from classic to bold, create a unique look.

BASIC INFORMATION			
Product name		ACOUSTIC FLOORING PRODUCTS	
Sizes	Finished size		400*400mm 600*600mm Customizable
	Thickness	PET	9mm、12mm



1#



5#

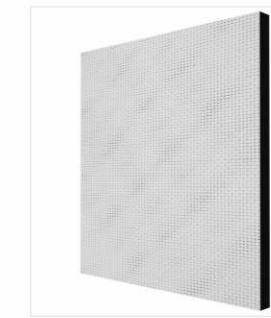
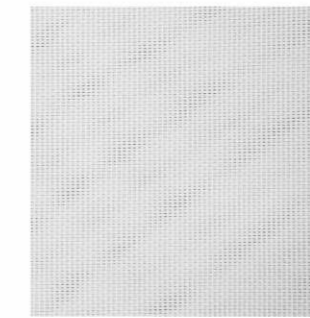

2#



6#

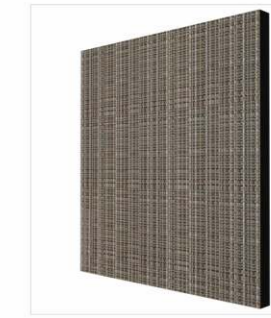

3#



7#



4#

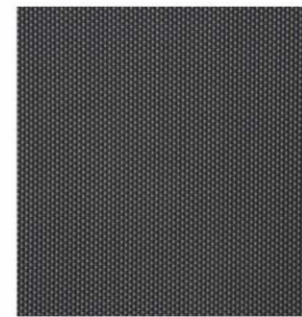

8#

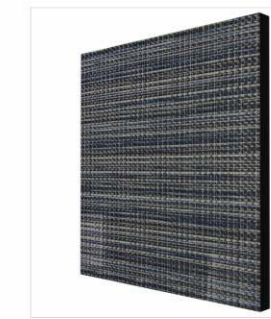

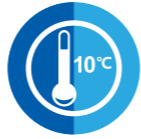

Specification 9mm*600mm*2440mm
9mm*650mm*2800mm

Linen series



TH-S101



TH-S104



TH-S105



TH-S102



TH-S106

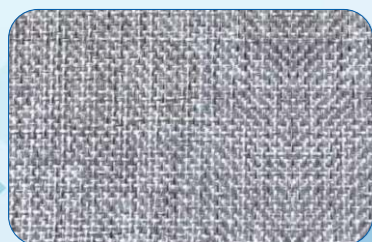

TH-S103

American wall cloth series



TH-S201



TH-S202



TH-S207



TH-S208



TH-S203



TH-S204



TH-S209



TH-S210



TH-S205



TH-S206



TH-S211



TH-S212

Cashmere series



TH-S301



TH-S305

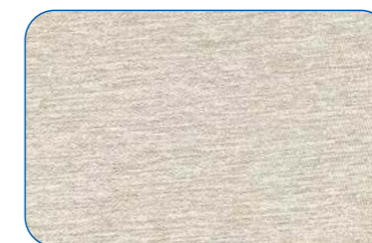

TH-S302

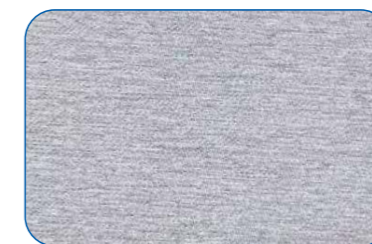

TH-S303

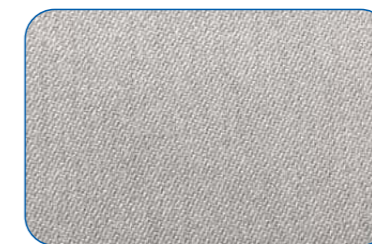

TH-S304

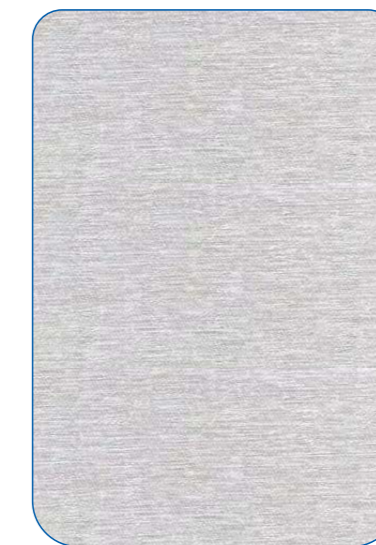

TH-S306

◀ **ENGINEERING CASE** ▶



GRID PANEL PRODUCT ENGINEERING



GRID PANEL PRODUCT ENGINEERING

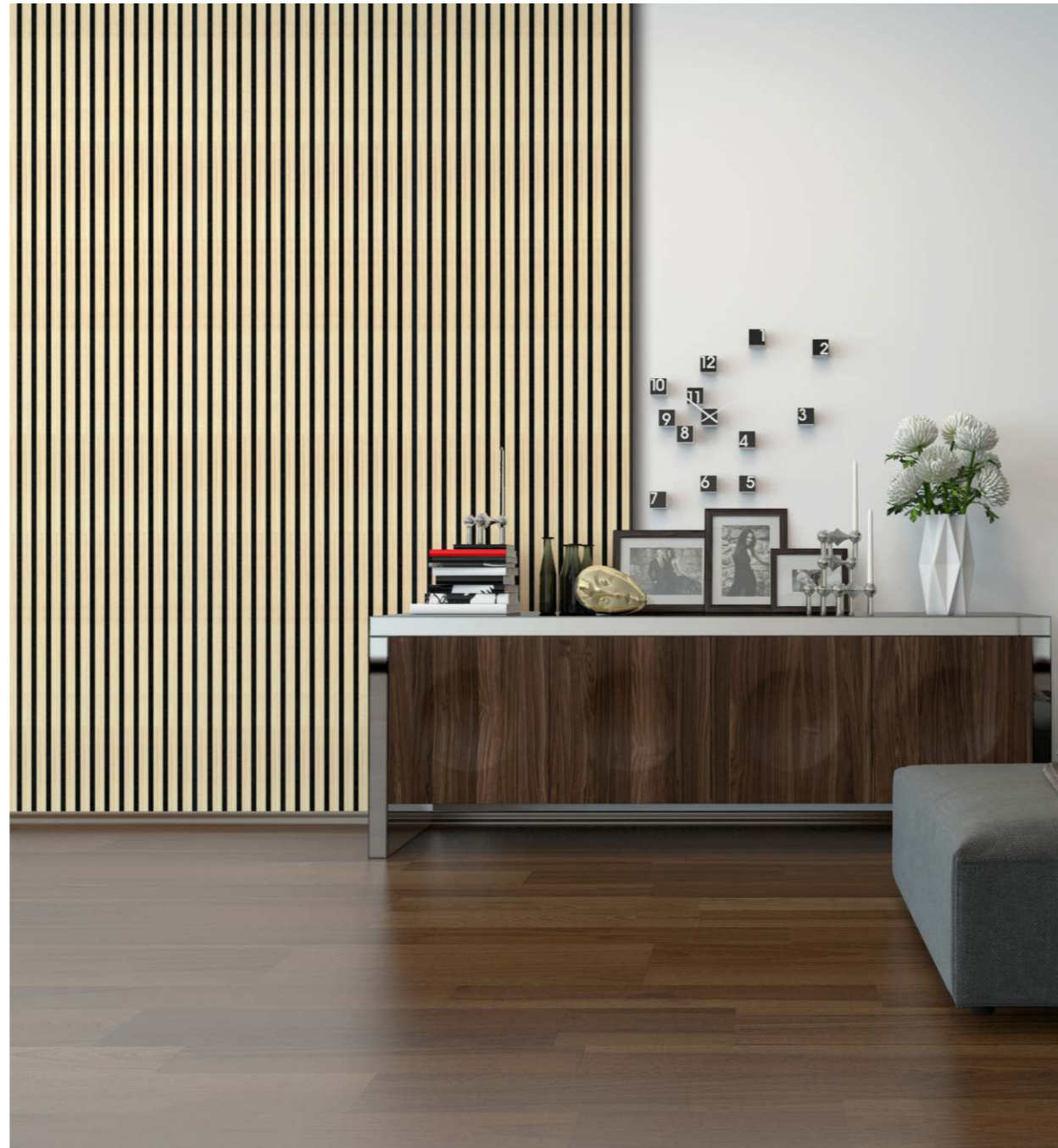

GRID PANEL PRODUCT ENGINEERING



GRID PANEL PRODUCT ENGINEERING



ACOUSTIC PANEL ENGINEERING



ACOUSTIC PANEL ENGINEERING

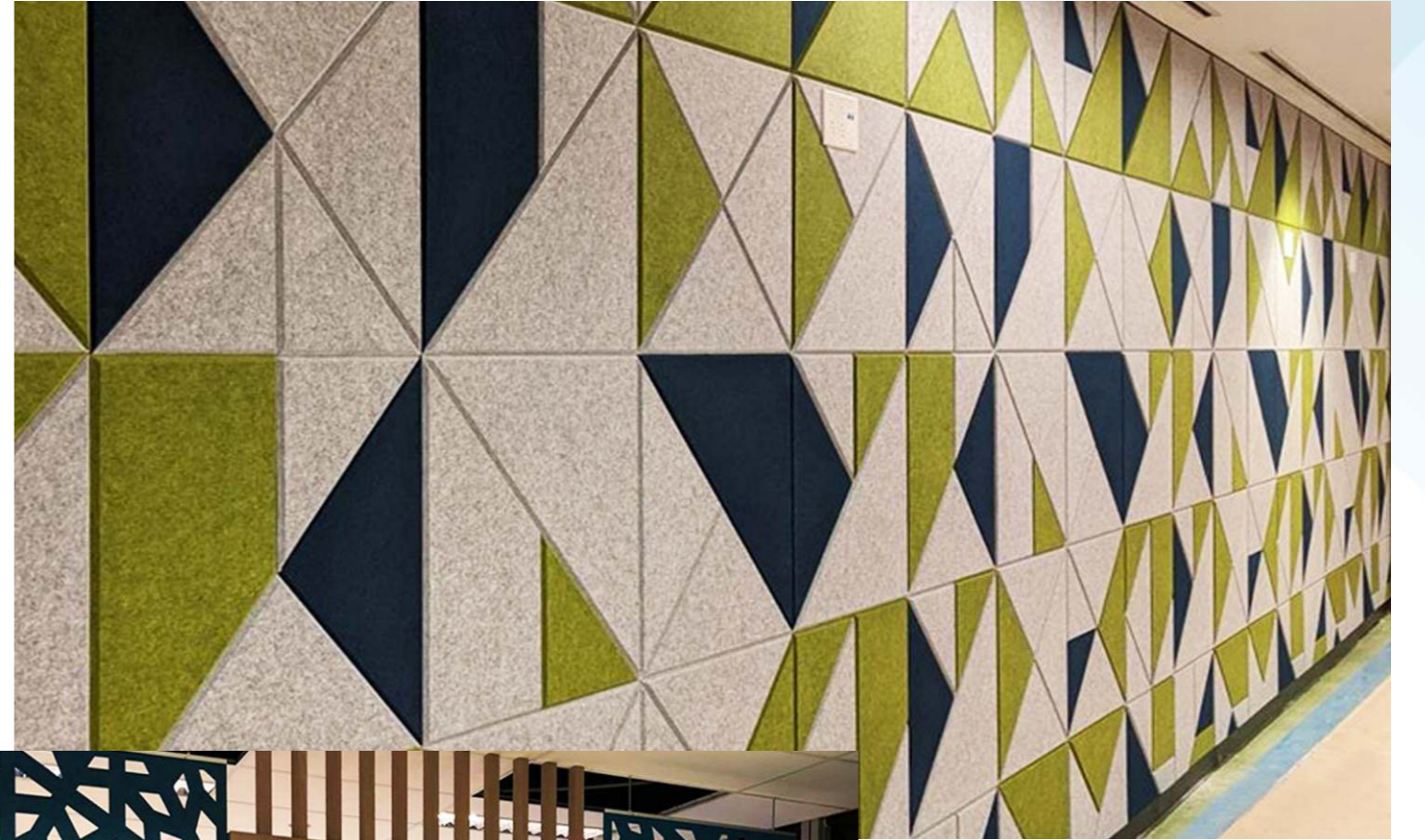

ACOUSTIC PANEL ENGINEERING



SCREEN GRATING PROJECT



ACOUSTIC FLOORING ENGINEERING

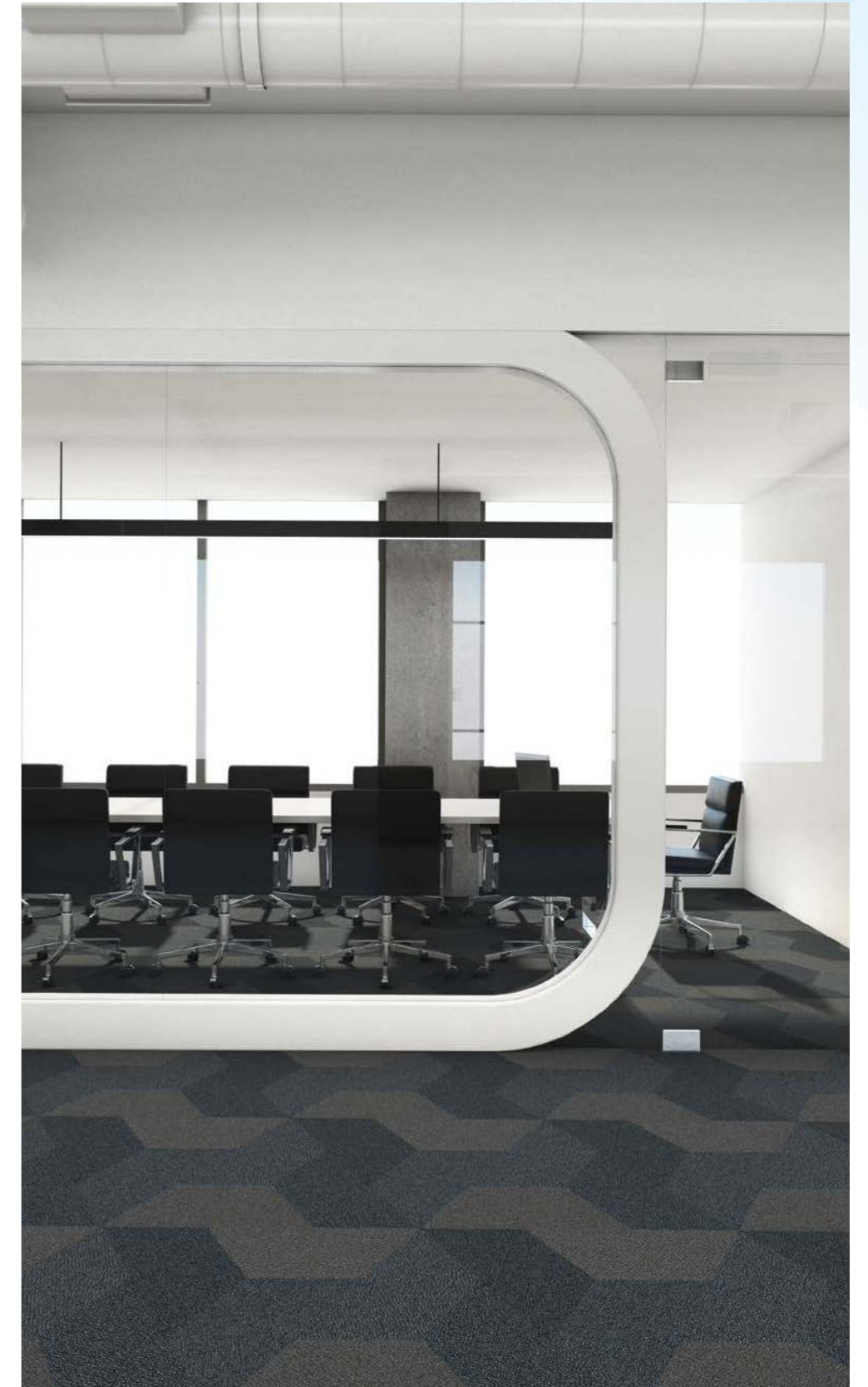

WALL PANEL ENGINEERING

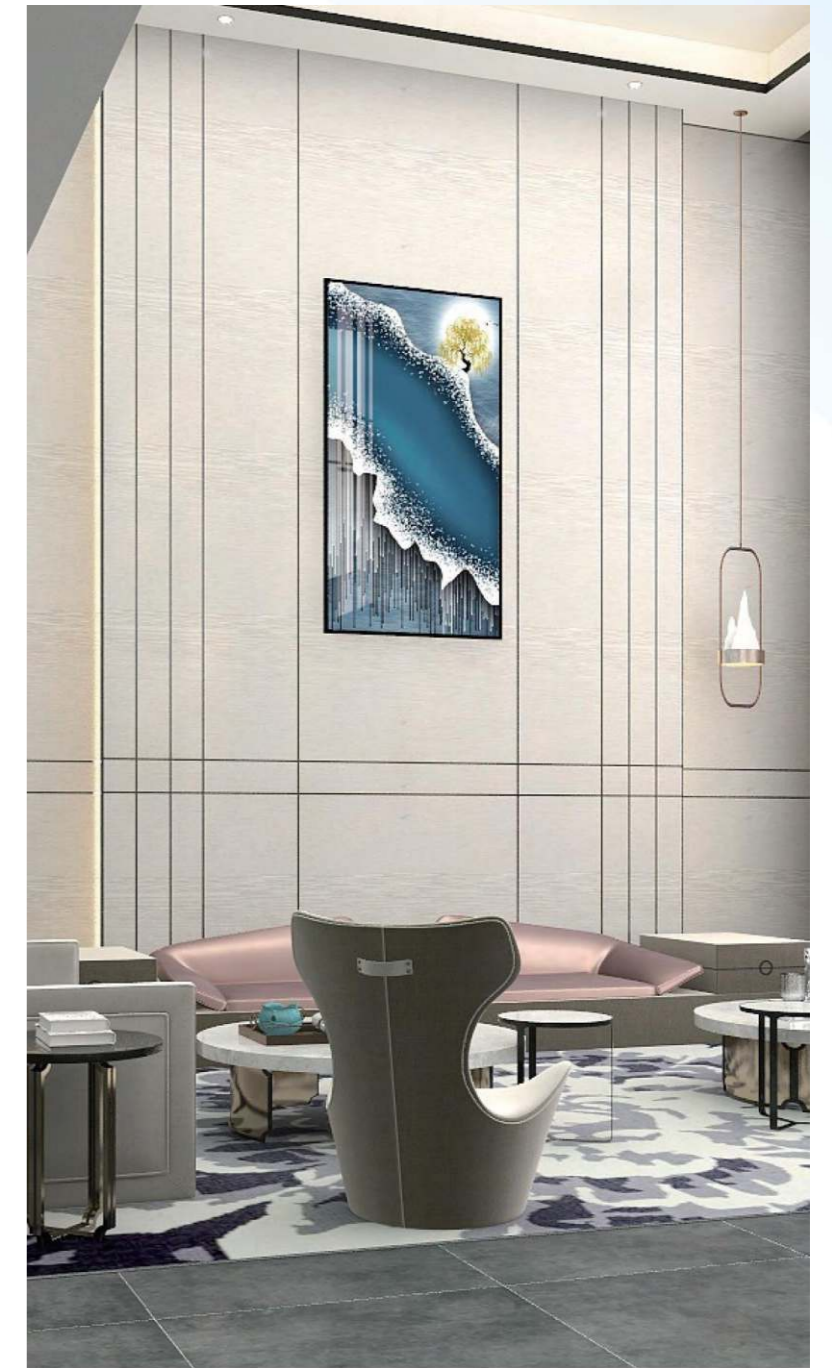

THANK YOU FOR WATCHING